

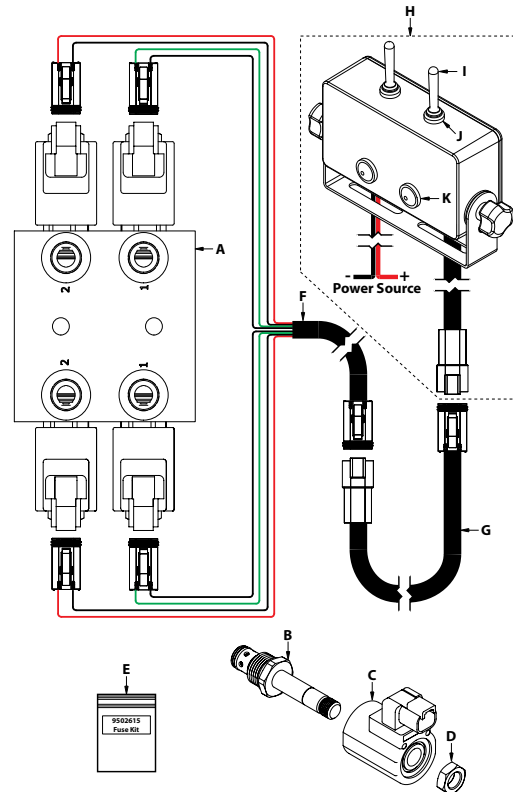

Installation Guide

Parts List

Part	Qty.	Description	Order #
A	1	Manifold	7068108
B	4	Valve, 2P2W, Poppet	7010128
C	4	Solenoid	7013763
D	4	Solenoid Nut	7013770
E	1	Fuse Kit	9502615
F	1	Solenoid Wire Harness	9502740
G	1	20' Extension Wire Harness	9502741
H	1	Switch Box/Wire Assembly	9502746
I	2	Toggle Switch	5056117
J	2	Toggle Boot	5056118
K	2	Indicator Light	5056138



Warning

To avoid serious injury or death:

- Park the equipment on level ground, apply the parking brake, disengage running equipment, lower all implements to the ground, shut off the engine and remove the key.
- Read and comprehend the tractor and implement or attachment owner's manual before installing or operating this valve.
- Always wear safety glasses and proper personal protection equipment before and during installation of this valve.
- Pressurized hydraulic fluid can cause serious injury. The forces created can penetrate skin. Relieve all system pressure before disconnecting lines. Be sure that the equipment is in a "zero-energy" state. Before applying pressure and flow to this valve, be sure that all connections are tight and the hydraulic hoses are not damaged in any way. Hydraulic fluid can leak from pin-holes and cause injury. Visually inspect all connections and never use your hands or fingers to inspect for leaks. If you are injured by injection of hydraulic fluid, see a doctor. Failure to do so may cause serious injury or death.

Step 1 - Valve Mounting

Note: Ports in the valve are #8 SAE o-ring. DO NOT use Teflon tape, rector seal, liquid anaerobic, pipe dope etc. on the threads. NO THREAD SEALANT IS REQUIRED. It is important to pre-lube the o-rings with hydraulic fluid before installing the fittings into the valve body. Valve mounting is unrestricted. Mount the valve in any position. Be sure that the tops of the solenoids does not contact metal. The two mounting holes accept 3/8" bolts. The bolts should be at least 2-1/2" long to clear the manifold.

Step 2 - Electrical Installation

Disconnect the negative battery terminal before installing.

CAUTION: The valve should be mounted and connected to the wiring harness before the control switch is connected to the power source. This will prevent accidental shorting of the control wires to ground.

Attach the red power wire to a keyed power source in your fuse-box. Make sure that the source of power is on only when the machine is in operation. This will prevent unwanted activation and possible battery drain. The black ground wire may be connected to the equipment frame or engine block. Metal-to-metal contact is required for a good ground. Paint or powder-coating may have to be removed to ensure a metal-to-metal ground.

If a fused 10-20 amp direct power source is not available on the equipment you are installing this valve control, use the included fuse kit (9502615). Use this kit to adapt the power connection to the keyed equipment fuse block. Instructions are included with the fuse kit. It is very important to fuse this valve control. Failure to fuse this valve control can cause damage and voids the warranty.

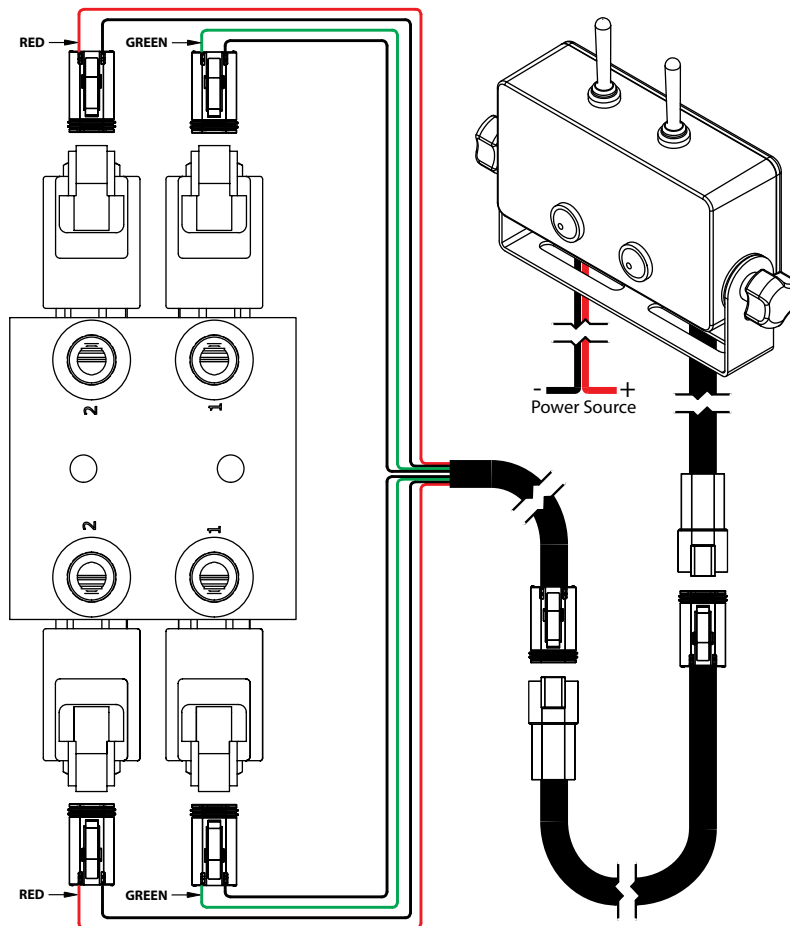

Step 3 - Hydraulic Plumbing

Follow the plumbing schematic as illustrated. Hoses are not provided as hose lengths vary per application.

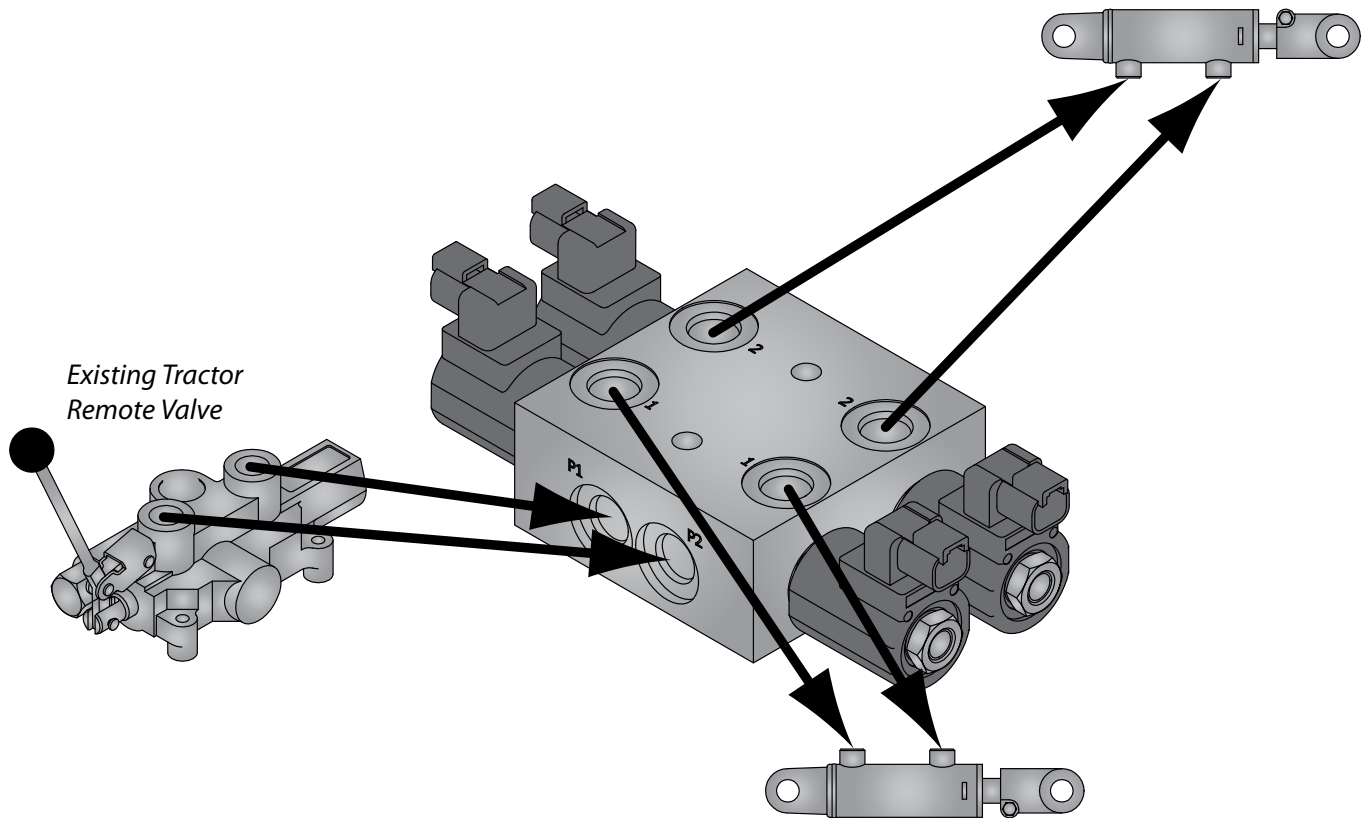

Operation

This poppet selector valve operates by energizing TWO solenoids when a toggle switch is activated.

The cylinder located on the ports labeled "1" will operate when the corresponding toggle switch is activated.

The cylinder located on the ports labeled "2" will operate when the corresponding toggle switch is activated.

Directional control is controlled by the existing tractor remote valve located in the cab. This valve does not control direction of flow. The flow coming into "P1" or "P2" determines the direction of flow in the circuit.

CAUTION: Do not loosen or remove any fittings or the valve cartridge while there is pressure in the system or a load is being held up by the valve.

Maintenance

As with any piece of equipment, periodic maintenance will help provide longer life and trouble-free operation of your new PoppetPLUS system. Periodically inspect those electrical connections which are exposed to the elements for signs of corrosion or other damage. Replace any terminals that look as if they might fail in the field. Inspect the cable connecting the switch to the valve. Normal operation over time can cause a cable to move to a dangerous area. If the cable is in any danger of being crushed or cut, move it to a safer area and secure it. Check the hydraulic hoses connected to the valve. Wipe the body of the valve off and look for leaks. Tighten or replace any fittings you suspect of leaking. Inspect the hydraulic hoses for signs of leaking, cracking or bulging. Replace any hoses that show signs of failure.

Troubleshooting

If the valve was previously working, the trouble is most likely the result of a blown fuse, damaged wiring or a bad switch. If this is a new installation, carefully check the hydraulic connections to make sure that the valve is installed correctly as shown in the diagram. Also, inspect hydraulic coupler tips for proper mating. Incompatible couplers will usually not allow the ball or poppet to unseat properly and prevent a good hydraulic connection.

Electrical Troubleshooting

A simple way to determine if a solenoid is being energized is by touching the mounting nut on the valve coil with a screwdriver. The coil is an electromagnetic part and will attract the screwdriver when the power is on. If the screwdriver does not stick to the top of the coil, use a voltmeter to check for voltage between the coil terminal and the mounting nut. If the voltage is at least 11 volts, the valve should be functioning. When the coil is energized a click should be audible from the valve. The sound may be quiet or muffled if the valve is under pressure. If the voltage is low, check the voltage at the source where the power wire for the control was connected. If no voltage is found, try measuring the voltage between the coil terminal and the tractor frame. If voltage is indicated, the valve is not being grounded. Check the black ground wire. If no voltage is indicated between the coil power wire and the ground, first check the fuse and then the red wire to the switch control box.

Hydraulic Troubleshooting

If none of the circuits work and the solenoid coils are being operated with at least 11 volts (measured at the coil), check that the supply connections from the tractor remote to the valve are correct. Check that the cylinders are connected to the valve as shown in the diagram. If necessary, remove the valve and connect the cylinder to the remote outlet to confirm that the supply hoses and coupler tips are in working order.



Warning

To avoid serious injury or death:

- Use extreme care to make sure all individuals are safely clear from equipment and the nearby area whenever operating remote valve control switches.
- Operating electrical controls (even when the remote lever is in neutral or the engine is stopped) will result in the valves operating and may result in equipment moving suddenly without warning. Stay clear of all valves, lines, cylinders and what cylinders operate when using the controls.

