

Electric Directional Control Stack Valves

17 GPM

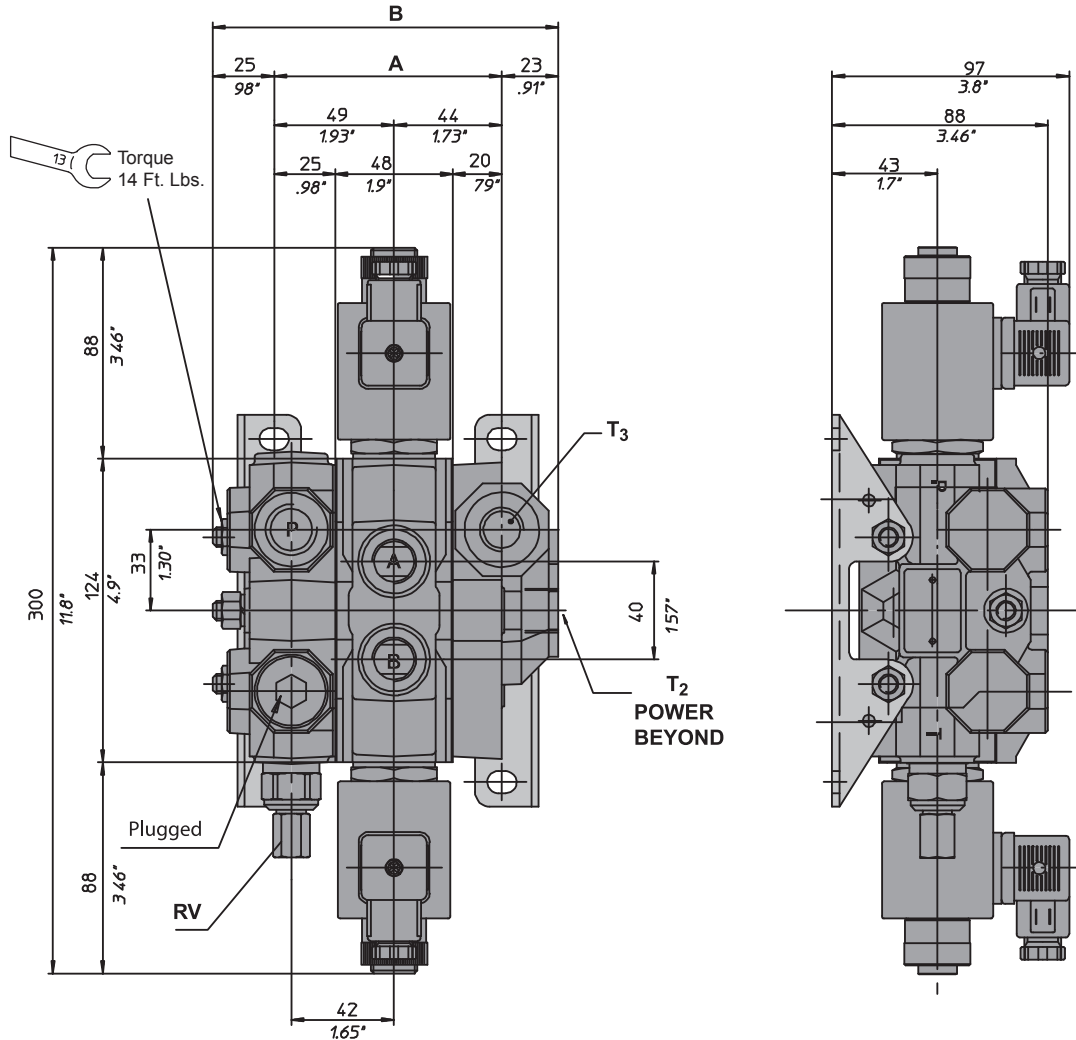

Dimensions



Dimensional data shown in mm and inches

Ex.: 63.5 = mm
2.50" = inches

	1 Work Section	2 Work Sections	3 Work Sections	4 Work Sections	5 Work Sections	6 Work Sections	7 Work Sections	8 Work Sections
Dimension A - mm	93.0	141.0	189.0	237.0	285.0	333.0	381.0	429.0
Dimension A - inches	3.66"	5.55"	7.44"	9.33"	11.22"	13.11"	15.00"	16.89"
Dimension B - mm	141.0	189.0	237.0	285.0	333.0	381.0	429.0	477.0
Dimension B - inches	5.55"	7.44"	9.33"	11.22"	13.11"	15.00"	16.89"	18.78"
Tie-Rod	7153852	7153892	7153858	7153878	7153864	7153902	7153904	7153888

*QTY 3 tie-rods required

**Contact a sales representative for more information on mixing manual and electric work sections.

