

Rodless Cylinders Series 50

Double-acting, magnetic, cushioned
 ø16, 25, 32, 40, 50, 63, 80



- » Four ports on each chamber
- » Possibility to supply both chambers from one side (on request)

The Series 50 rodless cylinders are available in 7 different diameters to cover as many applications as possible. A permanent magnet is assembled on the cylinder piston allowing the position to be detected by means of proximity switches positioned on the sliding axis. This series of cylinder is normally supplied with end-stroke cushioning, that can be regulated by means of a screw located on the end-cover.

The Series 50 cylinders are recommended to be used according to the load values and torque forces detailed in the relative tables.

GENERAL DATA

Type of construction	rodless with integral carriage
Operation	double-acting
Materials	end-covers, piston and barrel = AL seals = PU and NBR
Type of mounting	foot mounted
Strokes min - max	for all bores 100 – 4000 mm
Operating temperature	0°C – 50°C (with dry air - 10°C), (32 F - 122 F , with dry air down to 14 F)
Operating pressure	1 – 8 bar, (14 - 116 psi)
Speed	10 – 1000 mm/sec (without load)
Fluid	clean air, without lubrication If lubricated air is used, it is recommended to use oil ISOVG32. Once applied the lubrication should never be interrupted.

CODING EXAMPLE

50	M	2	P	50	A	0500
----	---	---	---	----	---	------

50	SERIES
M	VERSION M= standard magnetic
2	OPERATION 2 = double-acting cushioned
P	MATERIALS P = anodized AL profile tube - PU and NBR seals - standard carriage U = anodized AL profile tube - PU and NBR seals - flanged carriage
50	BORE 16 = 16 mm 25 = 25 mm 32 = 32 mm 40 = 40 mm 50 = 50 mm 63 = 63 mm 80 = 80 mm
A	TYPE OF MOUNTING A = standard
0500	STROKE (see table)

MAXIMUM PERMITTED LOADS AND TORQUE FORCES

$M = F \times b$
 $MS = F \times b$
 $MV = F \times b$

Note: Loads and bending torque are valid if applied separately.

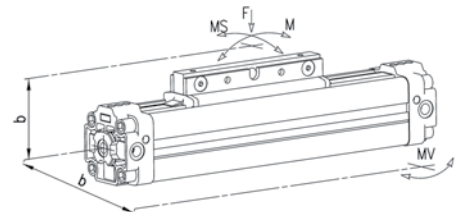

Ø	Max. load permitted (N) F	Max. bending torque force permitted (Nm) M	Max. bending torque force permitted (Nm) Ms	Torsional torque force permitted (Nm) Mv
16	218	3,1	0,5	1
25	660	12,4	1,9	5
32	720	30	4	8
40	1370	39	4	9
50	1600	122	11	16
63	2210	190	19	26
80	3770	305	30	47

4

LOADS ACCORDING TO SUPPORTS DISTANCE

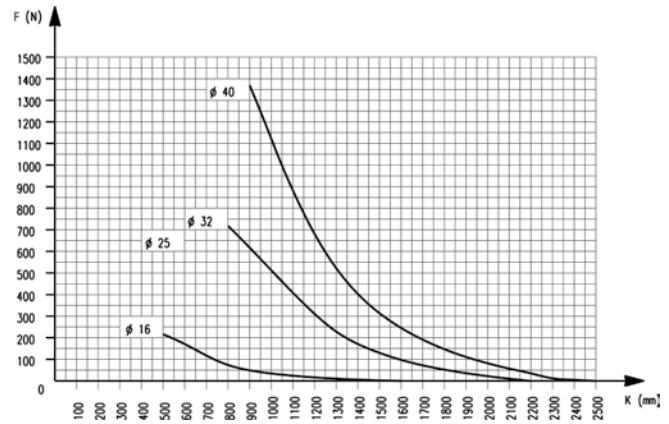
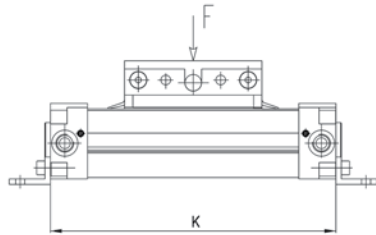

Note: This chart has been made according to a max. distance of 0.5 mm Load (N).
Once the load and the cylinder diameter have been fixed, the chart gives the K values beyond which it is necessary to put an intermediate feet Mod. BH-50.

LOADS ACCORDING TO SUPPORTS DISTANCE

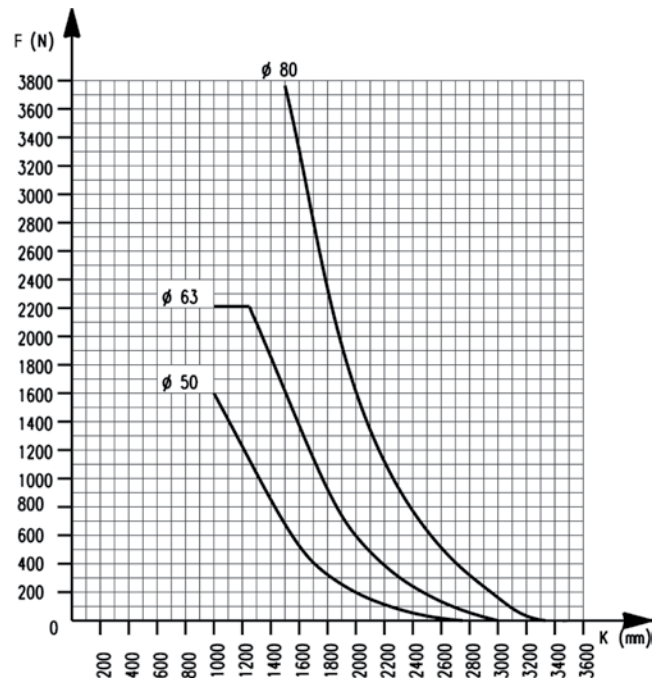
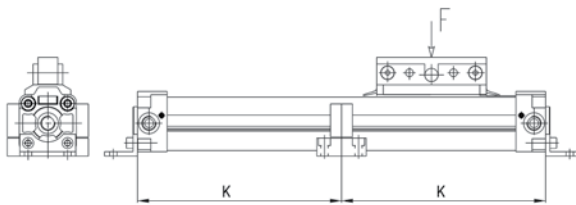

Note: This chart has been made according to a max. distance of 0.5 mm Load (N).
Once the load and the cylinder diameter have been fixed, the chart gives the K values beyond which it is necessary to put an intermediate feet Mod. BH-50.

Cylinders with standard carriage Mod. 50M2P

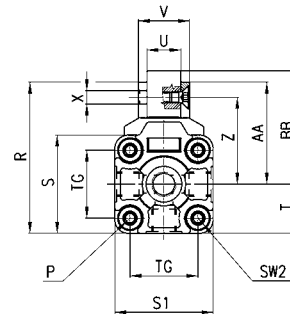
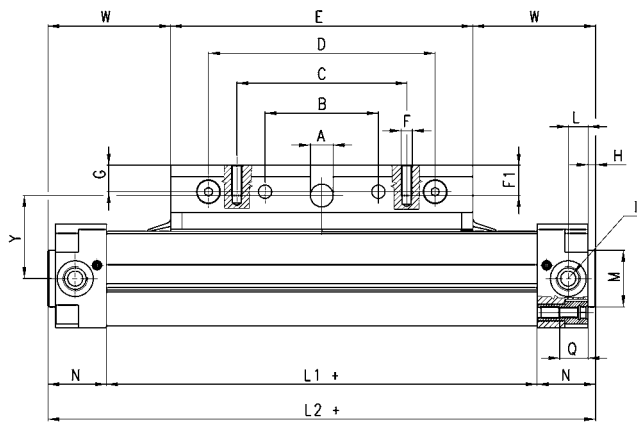

DIMENSIONS (mm)

Ø	A	B	C	D	E	F	F1	G	H	I	L	L1+	L2+	M	N	P	Q	R	S	S1	T	U	V	Z	X	Y	W	AA	BB	TG	SW2
16	5	32	48	64	76	M4	8	6	2	M5	5,3	100	130	16	15	M3	8	42,5	28	27	13,5	10	18	24	4,5	24,5	27	29	30	18	4
25	8	50	80	100	120	M5	10	13	2,5	G1/8	9,5	150	200	22	25	M5	13,5	63	40	40	20	15	23	33	5,5	38	40	43	46	27	6
32	12	60	90	120	160	M6	15	14	4	G1/4	10,5	188	250	30	31	M6	15	80	52	52	26	18	27	46	7	48,5	45	54	60	36	6
40	12	55	90	110	150	M6	12	12	4	G1/4	17,5	226	300	35	37	M6	15	88,5	63	63	31,5	18	28	49	7	51	75	57	61	43	6
50	12	70	110	140	180	M6	12	12	4	G1/4	13,5	272	350	40	39	M8	16	103	74,5	76	38	18	28	57	7	59	85	65	69	53	10
63	16	90	140	180	220	M8	15	15	4	G3/8	17,5	342	430	45	44	M8	16	125	92	94	47	19	30	68	9	70	105	78	83	67	10
80	20	120	180	240	280	M10	20	18	4	G1/2	32	408	520	45	56	M10	18,5	153,5	115,5	117	58,5	20	32	83	11	86	120	95	101	83	12

The company reserves the right to vary models and dimensions without notice. These products are designed for industrial applications and are not suitable for sale to the general public.

Cylinders with flanged carriage Mod. 50M2U

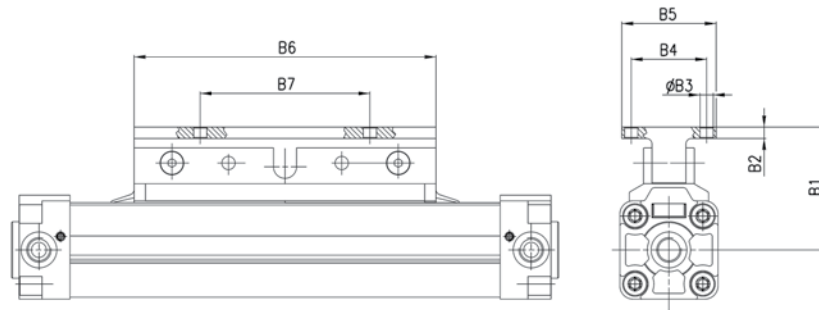

DIMENSIONS (mm)								
Ø	B1	B2	B3	B4	B5	B6	B7	
16	36	4	4,5	25	40	76	50	
25	51	5	5,5	35	50	120	70	
32	66	6	7	40	50	160	90	
40	66	6	7	45	60	150	80	
50	74	6	7	45	60	180	100	
63	89	7	9	60	80	220	130	
80	108	8	11	75	100	280	180	

Foot mount Mod. B-50



+ = add the stroke

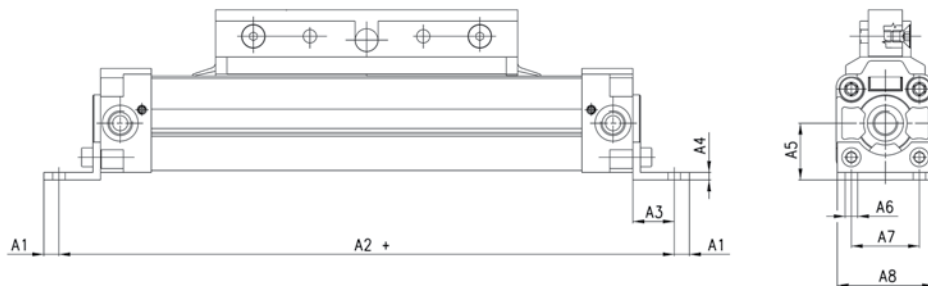

DIMENSIONS (mm)								
Mod.	A1	A2+	A3	A4	A5	A6	A7	A8
B-50-16	3	150	12	3	15	3,6	18	26
B-50-25	6,5	232	18,5	3	22	5,5	27	39
B-50-32	8	286	22	4	30	6,6	36	51
B-50-40	13,5	325	16,5	4	38	9	30	62
B-50-50	13,5	375	16,5	6	48	9	40	75
B-50-63	11	460	19	6	57	11	48	93
B-50-80	18,5	555	21,5	6	72	14	60	116

Brackets Mod. BH-50

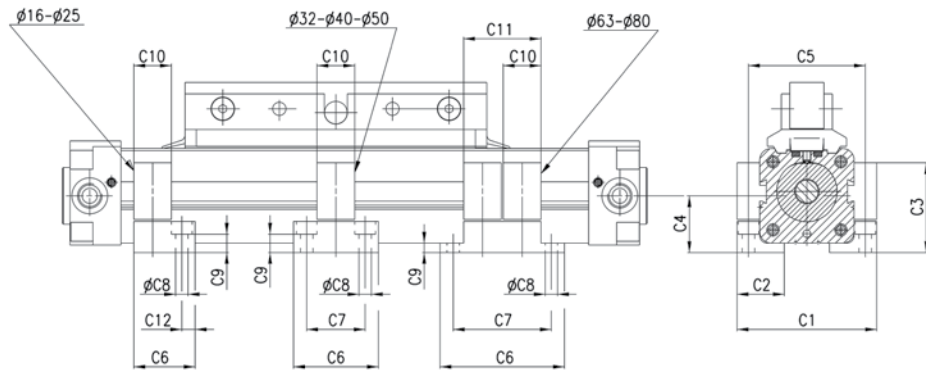

DIMENSIONS (mm)												
Mod.	C1	C2	C3	C4	C5	C6	C7	C8	C9	C10	C11	C12
BH-50-16	42	12	25	15	34	20	-	3,4	4,5	12	-	4
BH-50-25	56	21	32,6	22	47	22	-	5,5	10,1	12	-	5
BH-50-32	74	25	47,5	30	62	45	31	6,6	9,7	20	-	-
BH-50-40	85	35	56	38	73	60	45	6,6	18,2	20	-	-
BH-50-50	98	32	67,5	48	86	60	45	6,6	29,7	20	-	-
BH-50-63	126	50	78,5	57	109	74	56	9	11	20	41	-
BH-50-80	155	65	96	72	135	80	60	11	14,5	20	41	-

Self-compensating adaptor Mod. CF-50

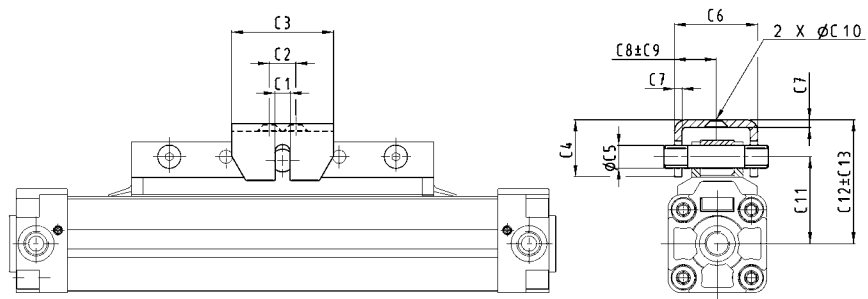

DIMENSIONS (mm)													
Mod.	C1	C2	C3	C4	C5	C6	C7	C8	C9	C10	C11	C12	C13
CF-50-25	6	16	40,8	22,9	7,9	31,5	3	15,8	1,2	5,6	38	55,4	4,5
CF-50-32	9,3	50	76,4	27,4	11,9	38,5	4	19	1,7	7,1	48,5	69,4	5,5
CF-50-40	9,3	50	76,4	24,4	11,9	38,5	4	19	1,2	7,1	51	70,9	3,5
CF-50-50	9,3	80	114,6	37,1	11,9	43,9	6	22	1,8	8,6	59	89,2	5,9
CF-50-63	12,7	100	134,6	42,2	15,9	43,9	6	22	0,8	8,6	70	104,7	6,5
CF-50-80	12,7	125	159,5	42,2	19,9	50,3	6	25,1	3	11	86	122,2	5

The company reserves the right to vary models and dimensions without notice. These products are designed for industrial applications and are not suitable for sale to the general public.