



Dual ReliefPLUS With Manual Dump 40 GPM Reliefs / Gauges Item# 9502896

This solution is designed specifically for tandem hydraulic pump setups. Here is the answer to clean up complicated and unsightly hydraulic plumbing on your truck's hydraulic system. Simply plumb this dual 'pressure & tank' manifold assembly into your truck's pressure lines from the pumps and to the return line going to tank. This valve acts as a main system reliefs with the added benefit of gauges to read system pressures. Reduce the headache of plumbing your truck today and utilize this professional hydraulic solution on your equipment. You'll be glad you did!

Benefits

- Hydraulic couplers can be mounted directly to the manifold
- Removes leak points
- Centralizes system components
- Easily plumbed
- Professional and clean appearance

Features

- Operating Pressure: 3500 PSI Maximum
- Flow: 40 GPM (Per Circuit)
- Pressure Ports: #16 SAE O-ring
- Tank Ports: #16 SAE O-ring, #24 SAE O-ring Main Tank Port
- Gauge Ports: #6 SAE O-ring
- Pressure and Tank Port Spacing: Accommodates 1" Wing Couplers
- Relief Valves: Pilot Operated, Preset At 3000 PSI, 300-3500 Adjustment
- Pressure Gauges: Liquid Filled, 0-5000 PSI, Dual Scale Includes Bar
- Installation: Unrestricted
- Hardware Included: Socket Head Cap Screws, Washers, and Nuts
- Temperature Range: -40°F to +212°F
- Hydraulic System: All, Fixed and Variable Displacement Pumps
- Construction: Aircraft Grade 6061 Aluminum
- Shipping Weight: 32 lbs.

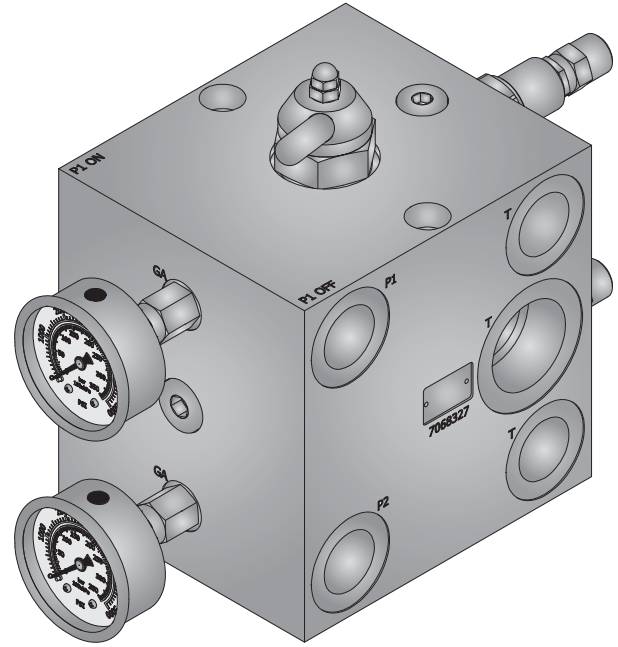

Typical Applications

- Turn your three and four line wet kit into a 2 line wet kit with a turn of a handle
- Pull a 4 line feed trailer one day and use your live bottom trailer the next
- Primarily used on trucks to limit system working pressure
- Used on any system where a pressure limiting device is required

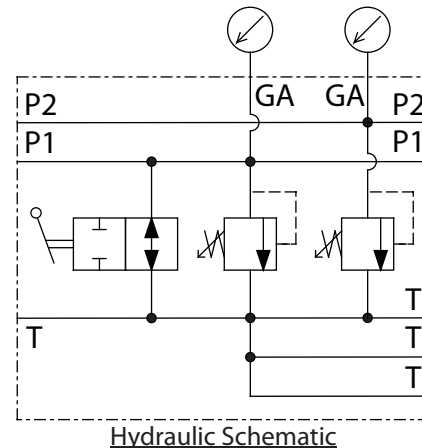

Dual ReliefPLUS Truck Frame Mounting Kit

Item# 9502872

Mounting your Dual ReliefPLUS a breeze when utilizing this mounting kit. This mounting kit is made for the Dual ReliefPLUS.

Benefits

- No drilling holes into the frame
- Universal mounting kit fits most trucks
- Professional and clean appearance
- Can be removed and reassembled on another truck

Features

- Heavy Duty 1/4" Steel Construction
- Black Powder Coat Finish
- Includes All Necessary Hardware
- Angles Coupler Connections Upward
- Angles Pump and Tank Connections Downward

