

Male J.I.C. (37°) X Male Pipe (N.P.T.F.)

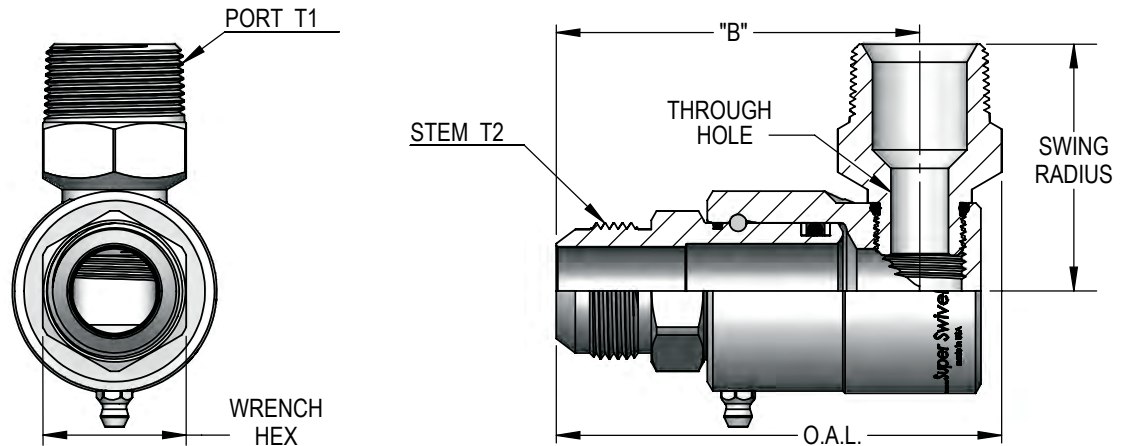

Not Available
In Stainless Steel!

PART NUMBER	O.A.L.	DIM. B	WRENCH/HEX	PORT T1	STEM T2	SWG. RADIUS	MAX. P.S.I.G.	THROUGH HOLE
9 SS 4 MJ 4 X MP 25	2.837	2.325	0.625	1/4-18 N.P.T.F.	7/16-20 U.N.	1.440	3500	0.172
9 SS 4 MJ 6 X MP 25	2.857	2.345	0.625	1/4-18 N.P.T.F.	9/16-18 U.N.	1.440	3500	0.250
9 SS 4 MJ 6 X MP 38	2.857	2.345	0.625	3/8-18 N.P.T.F.	9/16-18 U.N.	1.440	3500	0.250
9 SS 8 MJ 8 X MP 38	3.060	2.513	1.000	3/8-18 N.P.T.F.	3/4-16 U.N.	1.556	3500	0.297
9 SS 8 MJ 8 X MP 50	3.060	2.513	1.000	1/2-14 N.P.T.F.	3/4-16 U.N.	1.848	3500	0.297
9 SS 8 MJ 10 X MP 38	3.160	2.613	1.000	3/8-18 N.P.T.F.	7/8-14 U.N.	1.556	3500	0.250
9 SS 8 MJ 10 X MP 50	3.160	2.613	1.000	1/2-14 N.P.T.F.	7/8-14 U.N.	1.848	3500	0.297
9 SS 12 MJ 12 X MP 75	3.525	2.885	1.125	3/4-14 N.P.T.F.	11/16-12 U.N.	1.998	3500	0.484
9 SS 16 MJ 16 X MP 100	4.290	3.482	1.375	1-11 1/2 N.P.T.F.	15/16-12 U.N.	2.370	3500	0.550
9 SS 20 MJ 20 X MP 125	4.850	3.835	1.750	1 1/4-11 1/2 N.P.T.F.	15/8-12 U.N.	2.987	3500	0.827
9 SS 24 MJ 24 X MP 150	5.862	4.710	2.000	1 1/2-11 1/2 N.P.T.F.	1 7/8-12 U.N.	3.050	3500	0.944