

Directional Control Valves

LOG SPLITTER CONTROL VALVE

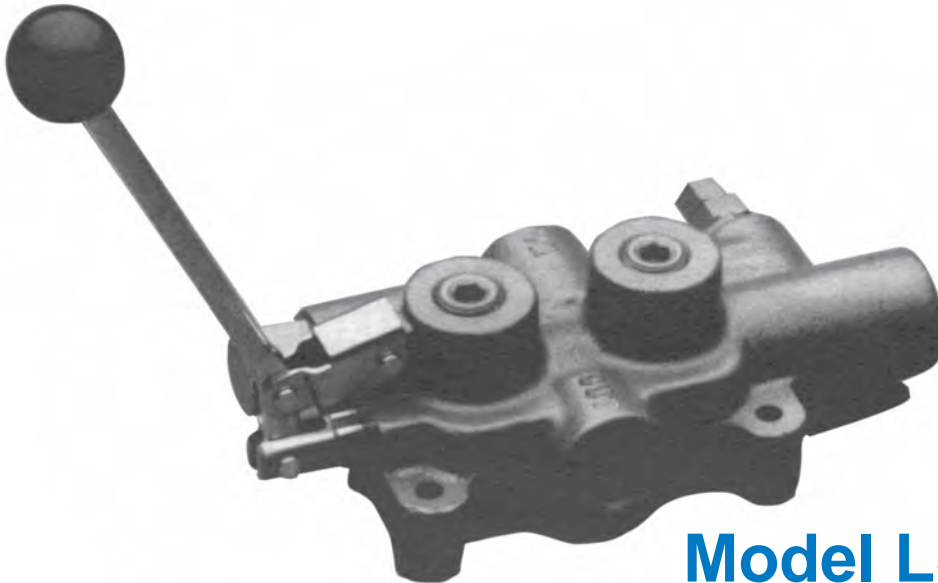

Model LS3000

SINGLE SPOOL MONO-BLOCK 20GPM

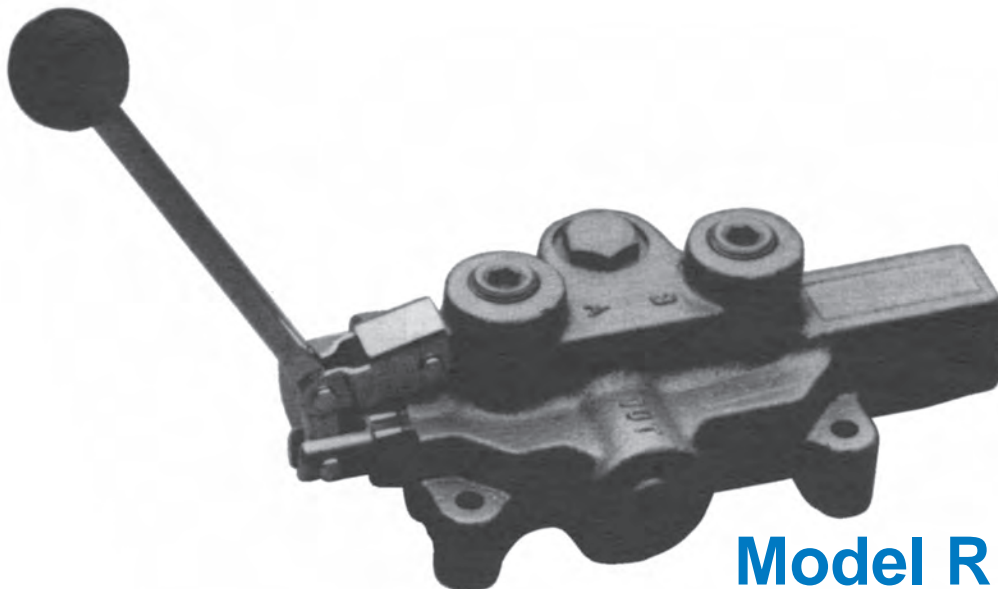

Model RD2500

MODEL LS3000 DIMENSIONAL DATA

On LS-3000 Models, pressure release detent is in the spool out position.
On LS-3060 Models, pressure release detent is in the spool in position.

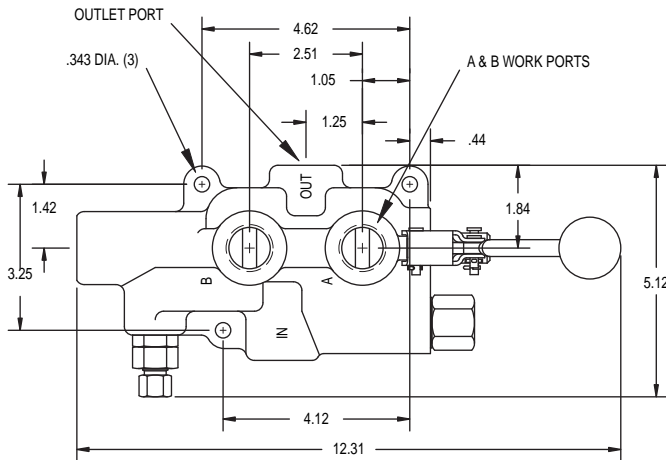

SPECIFICATIONS:

1. Max design and test pressure 2750 PSI
2. Max tank port pressure-150 PSI
3. Flow rating-25 GPM max.
4. Relief valve setting-2250 PSI
5. This valve has one position pressure release detent with spring center to neutral.
6. Weight: 10 lbs.
7. Recommended filtration-ISO 4406 19/17/14
8. Max operation temp-180°F
9. In exposed environments do not mount with spool vertical and handle end down.

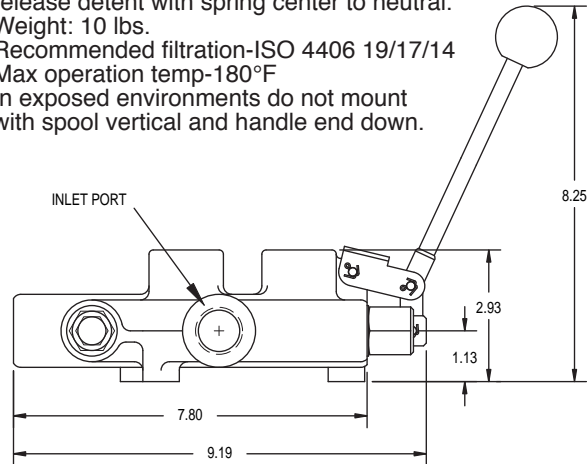

STANDARD FEATURES

- Hydraulically balanced, hard chrome plated spool
- Handle can be installed in "up" or "down" position
- Detent release pressure adjustable from 1000 to 2000 PSI
- For use with system flows up to 25 GPM
- Relief valve adjustable up to 2750 PSI
- Tandem center spool (in neutral position, both work ports blocked, pump unloaded to tank)
- Ideal for log-splitter applications. Available with 3/4" NPTF work ports for higher flow applications

PARTS LIST - LOG SPLITTER VALVES

ITEM	PART NUMBER	DESCRIPTION
1	660130001	HANDLE KIT
2	660125004	RELIEF KIT
3	660130004	SPRING CENTER KIT
4	660330003	DETENT SLEEVE & PISON SUB-ASSY
5	660330002	DETENT ADJUSTING CARTRIDGE
6	660130007	COMPLETE PRESSURE RELEASE DETENT KIT
7	660530001	SEAL KIT (CONTAINS SEALS FOR SPOOL AND DETENT)

MODEL LSR-3060 RAPID EXTEND LOG SPLITTER VALVE

STANDARD FEATURES

- Hydraulically balanced, hard chrome plated spool
- Handle can be installed in "up" or "down" position
- Extend flows of up to 25 GPM with inlet flows of 4 GPM
- Relief valve adjustable up to 3500 PSI
- Tandem center spool
- Manual shift from high speed mode to high force mode
- Spring center 4 position spool with soft stop
- Pressure release detent on retract

FUNCTION:

The Prince LSR-3060-3 log splitter valve features an extremely fast "Rapid Extend" high speed mode. The LSR has been specifically designed to reduce system costs by allowing a single stage pump to be used in systems currently using two stage (hi-low) pumps. When extra splitting force is required, the LSR allows the user to manually shift from high speed mode to high force mode. A "soft stop" differentiates between high force and high speed modes. Laboratory testing has not shown a significant difference in working cycle times between single stage/rapid extend systems and two stage systems. (Working cycle is the average time between extending the cylinder to split the first log and extending to split the next log after the split wood has been removed and a new log has been placed on the log splitter.)

SPECIFICATIONS:

1. Max design and test pressure 3500 PSI
2. Max tank port pressure -150 PSI
3. Nominal inlet flow rating 4 gpm
4. Standard relief valve setting - 2250 psi
5. This valve has a pressure release detent from spool in w/ spring center to neutral
6. The valve has a 4 position spool with normal extend and retract positions and a 4th rapid extend position
7. Max operating temperature - 180°F.
8. In exposed environments, do not mount with spool in the vertical position
9. Dimensionally similar to the LS3000 valve

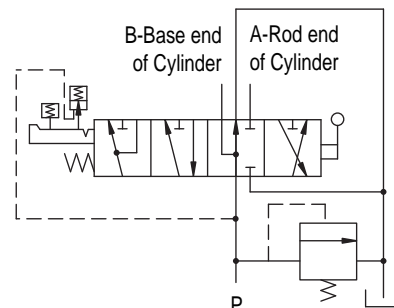

MODEL RD2500 DIMENSIONAL DATA

STANDARD FEATURES

- Economical monoblock construction of high tensile strength gray cast iron
- Load check
- Hard chrome plated spool
- Adjustable ball spring relief (1000 PSI to 3000 PSI)
- Open center to closed center conversion available on some models
- For use with system flows to 20 GPM
- For use with system pressures to 3000 PSI

SPECIFICATIONS:

1. Max design and test pressure 3000 PSI
2. Max tank port pressure-150 PSI
3. Flow rating-20 GPM max.
4. Relief valve setting-1500 PSI
5. Weight: 9.5 lbs.
6. Recommended filtration-ISO 4406 19/17/14
7. Max operation temp-180°F
8. In exposed environments, do not mount with spool vertical and handle end down.

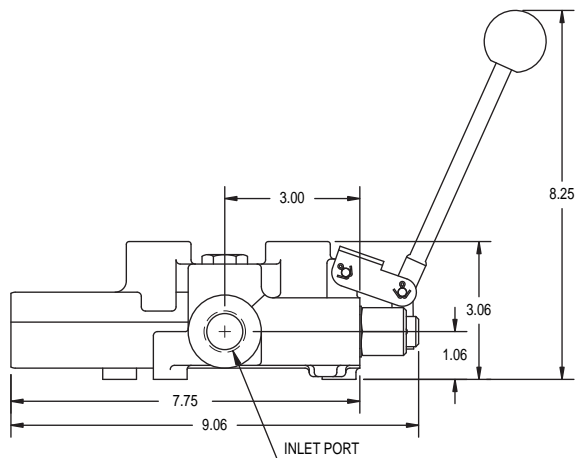
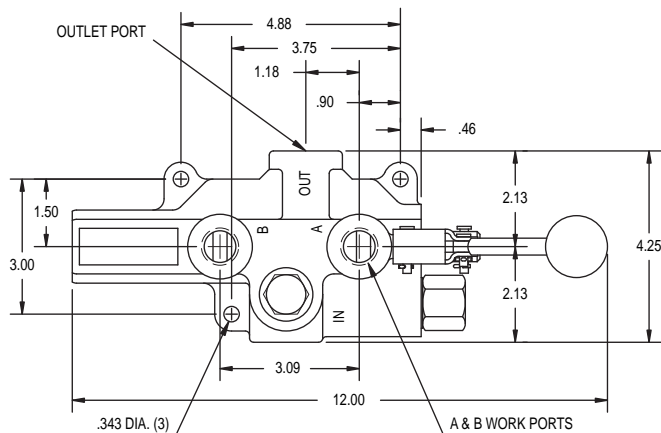

RD-2555-T4-ESA 1 PARTS BREAKDOWN

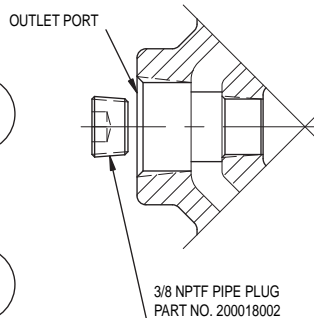
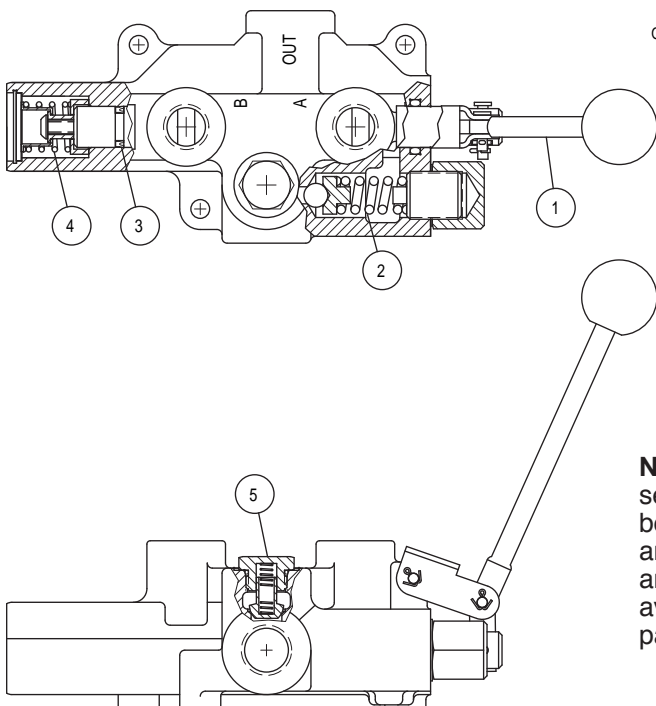

OPEN TO CLOSED CENTER CONVERSION This feature allows an otherwise open center valve to be converted to closed center operation. As shown, a 3/8 NPTF pipe plug is installed in the bottom of the outlet port to block open center passage. A pipe thread sealant should be used. This feature is standard on all valves with 3/4 NPTF inlet and outlet ports. The pipe plug is included with these models. Discard the pipe plug if the valve is used on an open center application. **PLEASE NOTE** that this closed center option does not provide for the drain off of standby spool leakage. This can allow a very small amount of oil to enter the work ports when in neutral.

NOTE: The Spool is select fit to the valve body at the factory and therefore body and spool are not available as repair parts.

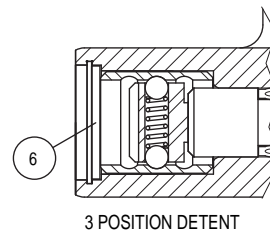

NON-STANDARD RELIEF SETTINGS RD2575-T4-ESA1-25

THE LAST TWO DIGITS ARE THE RELIEF SETTING IN HUNDREDS. Ex: 25=2500 PSI @ 12 GPM. ALL RELIEFS ARE SET AT 12 GPM.

ITEM	PART NUMBER	DESCRIPTION
1	660130001	HANDLE KIT
2	660125004	RELIEF KIT
3	660525001	SEAL KIT
4	660125002	SPRING CENTER KIT
5	660150015	LOAD CHECK KIT
6	660125001	3 POSITION DETENT KIT

LS-3000, RD-2500 PRESSURE DROP, RELIEF CURVE AND STANDARD MODELS

PRESSURE DROP

110 SUS OIL AT 115° Δ P-PSI						
FLOW (GPM)	RD-2500			LS-3000		
	INLET TO OUTLET	INLET TO A OR B	A OR B TO OUTLET	INLET TO OUTLET	INLET TO A OR B	A OR B TO OUTLET
5	5	20	8	3	5	4
10	9	39	15	5	11	13
15	19	60	32	7	23	24
20	31	90	54	11	40	42

LS-3000/RD-2500 RELIEF VALVE CURVES AT VARIOUS SET POINTS 110 SUS OIL AT 115°F

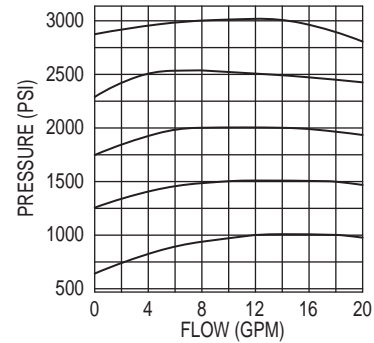

STANDARD VALVES AVAILABLE

All standard valves have a load check (except LS3000 models), a complete lever handle assembly, and an adjustable ball-spring relief, see below for settings. For other relief settings, please specify.

VALVE PART NUMBER	SPOOL TYPE			SPOOL ACTION			IN/OUT PORT SIZE	WORK PORT SIZE	RELIEF SETTING To Specify Other Settings See Next Page	CONVERTIBLE FROM OPEN CENTER TO CLOSED CENTER
	4 WAY 3 POSITION	4 WAY 3 POSITION MOTOR	3 WAY 3 POSITION	SPRING CENTER TO NEUTRAL	3 POSITION DETENT	PRESSURE RELEASE DETENT SPRING CENTER TO NEUTRAL				
RD-2555-T4-ESA1	X			X			1/2 NPTF	1/2 NPTF	1500 PSI @ 12 GPM	NO
RD-2575-T4-ESA1	X			X			3/4 NPTF	1/2 NPTF	1500 PSI @ 12 GPM	YES
RD-2575-T4-EDA1	X				X		3/4 NPTF	1/2 NPTF	1500 PSI @ 12 GPM	YES
RD-2575-T3-ESA1			X	X			3/4 NPTF	1/2 NPTF	1500 PSI @ 12 GPM	YES
RD-2575-M4-ESA1		X		X			3/4 NPTF	1/2 NPTF	1500 PSI @ 12 GPM	YES
RD-2508-T4-ESA1	X			X			#10 SAE	#8 SAE	1500 PSI @ 12 GPM	NO
RD-2575-M4-EDA1		X			X		3/4 NPTF	1/2 NPTF	1500 PSI @ 12 GPM	YES
LS-3000-1	X					X	3/4 NPTF	1/2 NPTF	2250 PSI @ 3 GPM	NO
LS-3000-2	X					X	3/4 NPTF	3/4 NPTF	2250 PSI @ 3 GPM	NO
LS-3060-1	X			X		X	3/4 NPTF	1/2 NPTF	2250 PSI @ 3 GPM	NO
LS-3040-1	X				X		3/4 NPTF	1/2 NPTF	2250 PSI @ 12 GPM	NO
LSR-3060-3	4 WAY 4 POSITION W/ MANUAL RAPID EXTEND					X	1/2 NPTF	3/4 NPTF	2250 PSI @ 3 GPM	NO

4 WAY SPOOL

This spool option is used to control a double acting cylinder. In neutral both of the work ports are blocked and oil goes through the open center passage to the outlet. This is the most popular spool option.

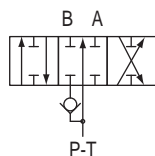

3 WAY SPOOL

This spool option is used to control a single acting cylinder or a uni-directional motor. In neutral the work port is blocked and oil goes through the open center passage to the outlet. The "B" work port is plugged for this option.

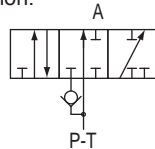

4 WAY MOTOR SPOOL

This spool option is used to control a reversing motor or a double acting cylinder. In neutral the work ports are connected to tank and oil goes through the open center passage to the outlet. This allows a motor to free-wheel or a cylinder to float in the neutral position.

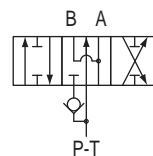

LOAD CHECK

The load check feature is standard on all RD-2500 valve models. The load check will prevent the fall of a cylinder as the spool is shifted. It does this by preventing the back-flow of oil from work port to inlet. The pump must build up enough pressure to overcome the pressure on the work port and lift the load check poppet. The load check has nothing to do with holding a cylinder when the spool is in neutral.