

**P Series, Equal Flow Two Sections**

Equal flow two-section units divide flow from a common pump source into separate flows of equal proportion. Both gear sets are assembled to a common shaft.

**PM2 & PM6**

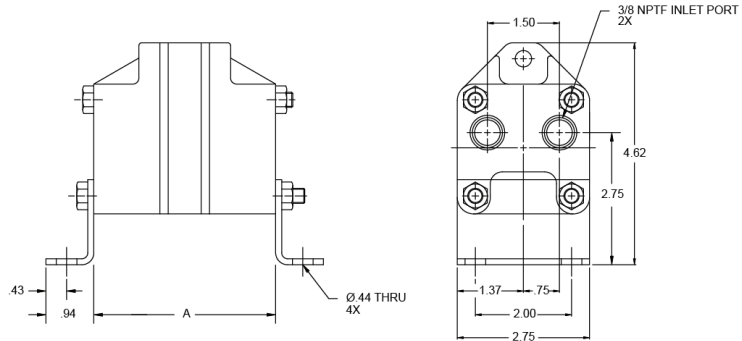

**P23 & P27**

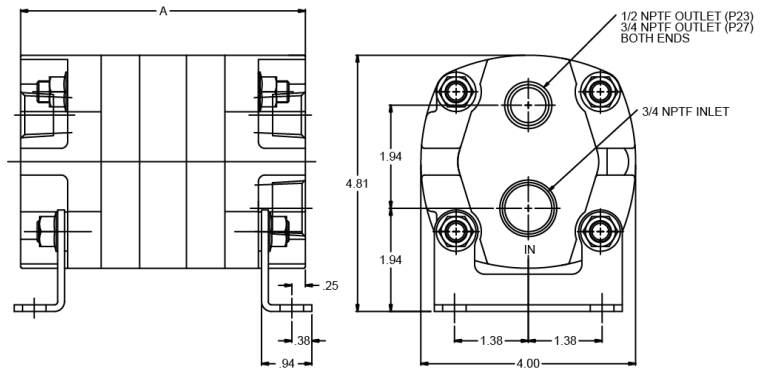

**P43 & P47**

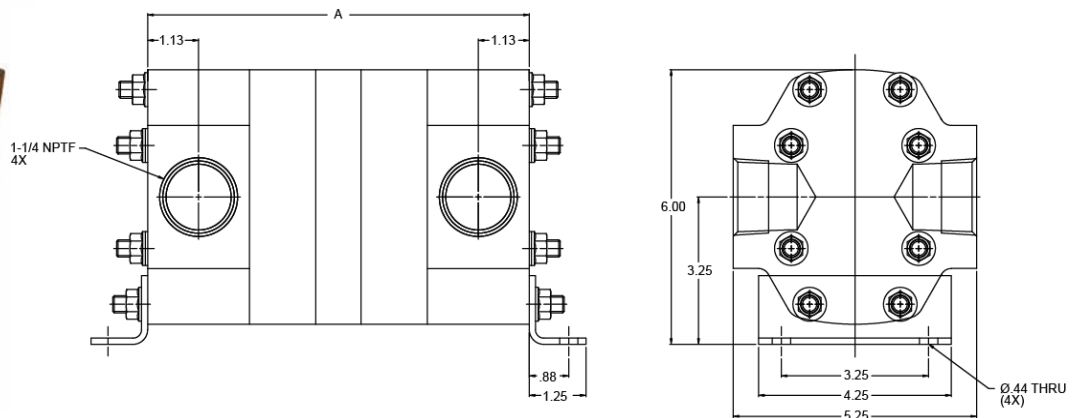

MODEL	NUMBER OF SECTIONS	TOTAL MAX. INLET (GPM)	0 PSI DISP. PER SECT. GAL./REV.	SLIP GPM/100 PSI	MAXIMUM INTERMITTENT PSI	MAXIMUM CONTINUOUS PSI	BOLT TORQUE Ft. Lb.	A	MAX. DIFF. BETWEEN SECT. (PSI)
PM2	2	3.5	0.00047	0.026	2500	2000	13-17	3.83	1500
PM6	2	9.5	0.00137	0.038	2000	1500	13-17	4.72	1000
P23	2	21.0	0.00304	0.068	2000	1500	24-31	5.32	1000
P27	2	44.0	0.00633	0.113	2000	1500	24-31	6.86	1000
P43	2	70.0	0.01020	0.135	2000	1500	24-31	7.75	1000
P47	2	100.0	0.01690	0.210	2000	1500	24-31	9.25	1000

**WARNING:** The specifications/application data shown in our catalogs and data sheets are intended only as a general guide for the product described (herein). Any specific application should not be undertaken without independent study, evaluation, and testing for suitability.