

Composite Push-In Fittings Double Stem Union Series 7950

Tube Diameter OD : 4, 6, 8, 10, 12, 16 mm

METRIC Tube Fittings				
DIMENSIONS (in mm)				
Model	B	L	L1	Weight (g)
7950 4	4	37	14	1
7950 6	6	39	15	1
7950 8	8	41	16	1
7950 10	10	44	18.5	1
7950 12	12	49	19	1



7950

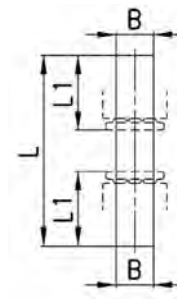

7950

Series 7000 push-in composite fittings are compact and lightweight. They offer easy maintenance of the collet and internal o-ring seal. All materials can be easily recycled.

The nickel-plated brass collect maintains the same technical characteristics as the other nickel-plated brass fittings. It provides a uniform grip around the entire surface of the plastic tube. This ensures high reliability and long service life, especially after several connections and disconnections of the tubing.

GENERAL DATA

Material	body: technopolymer (glass-reinforced Nylon 66 resin); insert: brass, collet: nickel-plated brass; seals: NBR
Threads	1/8", 1/4", 3/8", 1/2" NPTF with Pro-Fit® (reusable PTFE/Teflon thread seal) GAS cylindrical ISO-228 (BSP)
Operating pressure	min. -0.9 bar, max. 16 bar, (28" Hg vacuum to 250 PSI) (See data for tubing used)
Tube to connect	Nylon 6, 11 or 12, polyethylene, PU (polyurethane recommended 90A durometer and above) Hytel Polyester
Diameters	Tube Diameter OD: 5/32", 1/4", 5/16", 3/8", 1/2", 4 - 6 - 8 - 10 - 12 - 16 mm
Fluid	Compressed air
Temperature	-20° - 60°C (-4°F to 140°F)

Fitting with connecting tube

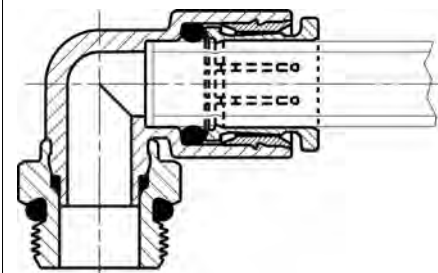

Composite Fittings: Threads with Pro-Fit®, Sprint® or Spot-Face O-Ring Seal

The technical solution: Camozzi has maintained the technically advanced and world-renowned collet solution by further optimizing the dimensions and the design from Series 6000 Fittings and Flow Control Valves.

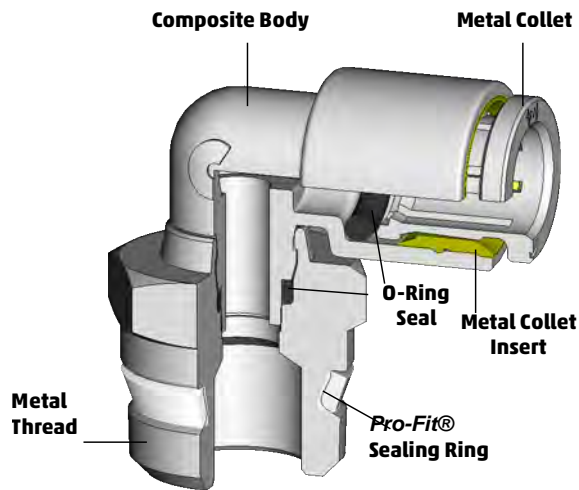

Durable Metal Collet: Nickel-Plated brass collet provides superior resistance to shock, wear and fatigue compared to inferior plastic collets. Proven metal design offers a higher holding force with easier tube release that won't scratch tubing like plastic "bite-ring" designs. Tube OD size is stamped on collet face.

Composite Body: Glass-fiber reinforced, thermoplastic material is incredibly strong and lightweight with improved resistance to UV exposure, abrasion and other chemical substances. Molded composite material allows for integral mounting holes and a broader range of complex shapes.

Pro-Fit® Thread Seal-Ring Design: Reusable Teflon seal reduces assembly time by up to 45% and eliminates exposed threads, making it ideal for food processing, robotics, packaging & manifold assemblies. Eliminates risk of pneumatic system contamination from thread sealants' residue.

Spot-Face O-Ring Thread Seal Design: Reusable Buna-N seal reduces assembly time by up to 45% and eliminates exposed threads, making it ideal for food processing, robotics, packaging & manifold assemblies. Eliminates risk of pneumatic system contamination from sealants' residue.

Features

Collet

- Nickel-Plated, All-metal Collet and Release ring
- Brass insert for collet support and tube grip strength
- Collet design offers greater grip strength under higher pressure or tubing tension
- Collet release mechanism based on relaxed slope of grip teeth, as opposed to disengaging "bite-rings" from partially cut tubes
- Removable Collet and tube o-rings

Body

- Glass-fiber reinforced, thermoplastic compact injection-molded body
- All-Metal, Nickel-Plated Threads
- Standard Buna-N or Specialized O-ring choices for High-Temp, Low-Temp, Special Fluids, Food-Grade compatibility
- Broad Range of shapes and configurations
- Crimp design on Swivels maintains Full ID Flow path
- Swivels offer Mechanical crimping lock based on brass design

Pro-Fit® and Sprint® Thread Design

- Multiple Thread sealant systems: **Pro-Fit®**/NPTF or BSP/**Sprint®**
- Full ID Flow for Swivels with high relief on larger sizes
- Eliminates exposed threads and fits into tight spaces, making them ideal for food processing and hygienic applications.
- Eliminates the need for Teflon® tape or pipe dope. Shorter thread length requires fewer turns to tighten.
- The captured Teflon® sealing ring provides a dependable and reusable shoulder seal without the risk of thread sealant contamination.

Benefits

Collet

- Won't break like plastic release rings, More Durable design
- Brass insert maintains collet stability, tube grip strength and consistent tube-release performance
- Higher holding force, with easier release
- Won't scratch tubes like "bite-ring" designs
- Less chance of micro-leakage and bubble-leaks over time due to damaged tubing
- Higher pressures actually offer greater grip-strength with high-pressure Nylon tubing
- OD Tube Size stamped on Collet face

Body

- Thermoplastic Nylon composite more resistant to UV exposure
- Better resistance to stress-cracking, abrasion, solvents, detergents & hydrocarbons
- 15% Reduction in overall Body size, (24% in Assembly height/ 8% in Tube Radius), compared to recently reduced-size Brass line

Thread Design

- Reduced assembly time without taping of fitting threads
- Re-usable seal design, with no exposed threads
- Simplified manifold circuits with broader variety of fitting combinations and shapes to select
- Lighter weight for End-of-Arm tooling & Robotic handling
- Compact design reduces overall dimensions for valve assemblies, packaging applications and control cabinets