

DG-FDB FLOW DIVIDER VALVE, SPOOL TYPE

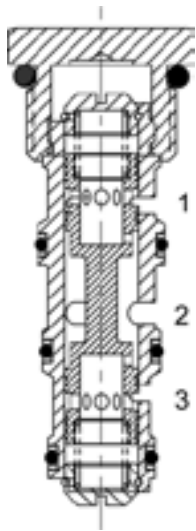

DESCRIPTION

10 size, 7/8-14 thread "Delta Series", spool type, flow divider.

OPERATION

The DG-FDB will divert input flow from port (2) to ports (3) and (1), based on the ratio specified, regardless of operating pressure. Should circuit operation result in a blockage of either (3) or (1), the opposite port may also close under certain conditions. Should this potential exist, consult the factory.

FEATURES

- Hardened parts for long life.
- Industry common cavity.



DO NOT EXCEED MAXIMUM FLOW PER MODEL.

HYDRAULIC SYMBOL

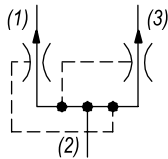

PERFORMANCE

Actual Test Data (Cartridge Only)

VALVE SPECIFICATIONS

Maximum Flow	12 GPM (45 LPM)
Accuracy on Flow Splits	±10% of Max Rated Inlet Flow
Maximum Operating Pressure	3500 PSI (241 bar)
Viscosity Range	36 to 3000 SSU (3 to 647 cSt)
Filtration	ISO 18/16/13
Media Operating Temp. Range	-40° to 250°F (-40° to 120°C)
Weight	.21 lbs (.10 kg)
Operating Fluid Media	General Purpose Hydraulic Fluid
Cartridge Torque Requirements	30 ft-lbs (40.6 Nm)
Cavity	DELTA 4W
Cavity Form Tool (Finishing)	40500002
Seal Kit	21191214

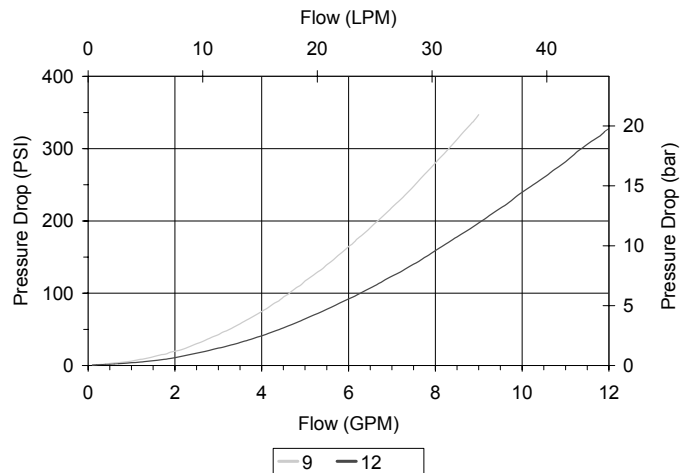
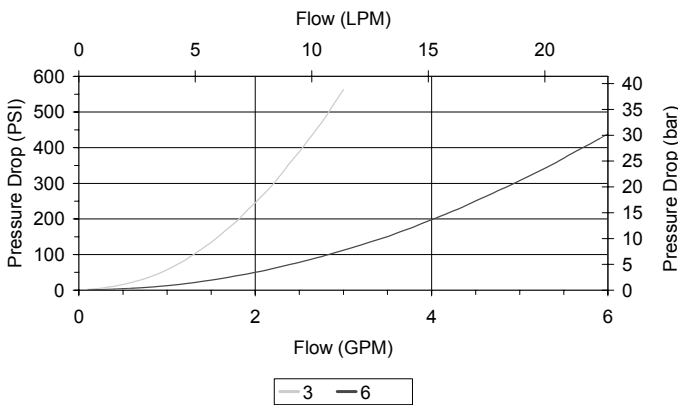

WARNING: the specifications/application data shown in our catalogs and data sheets are intended only as a general guide for the product described (herein). Any specific application should not be undertaken without independent study, evaluation, and testing for suitability.



4484 Boeing Drive Rockford, IL 61109 • USA • Phone +1 (815) 397-6628 • Fax +1 (815) 397-2526
 mail: delta@delta-power.com • www.delta-power.com



Via Malavolti, 36 • 41122 Modena • ITALY • Phone +39 (059) 254895 • Fax +39 (059) 253512
 mail: tecnord@tecnord.com • www.tecnord.com

DIMENSIONS

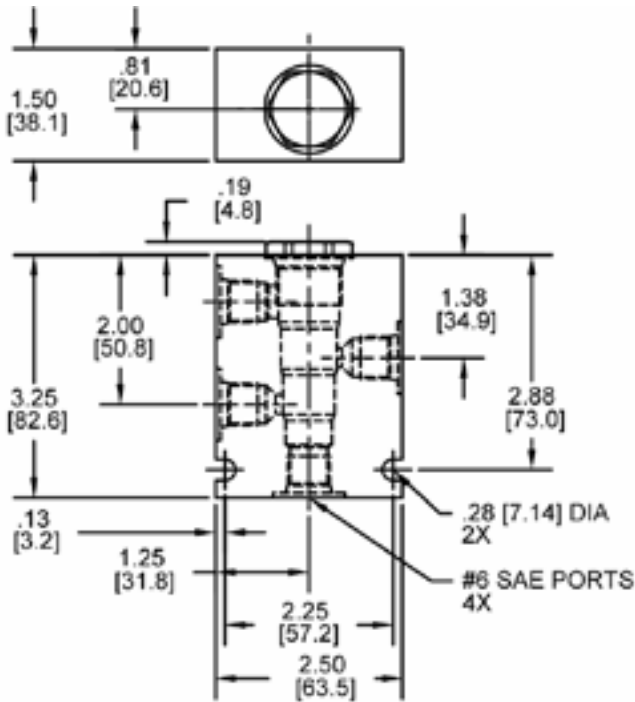
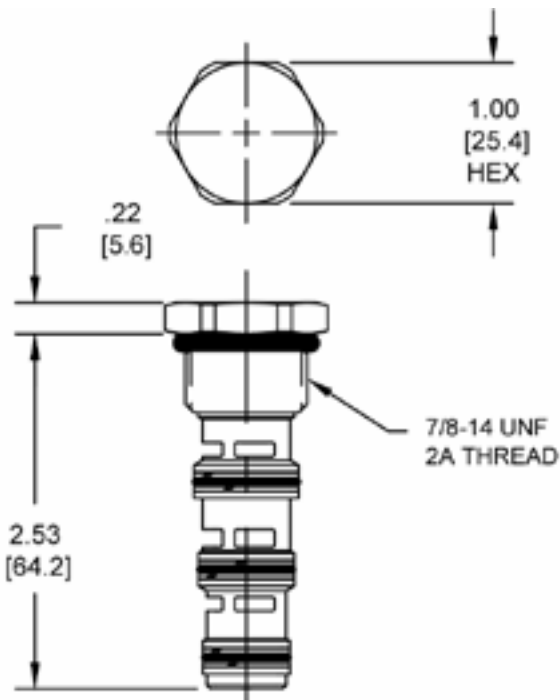

Body Weight: .99 lbs (.45 kg)

ORDERING INFORMATION

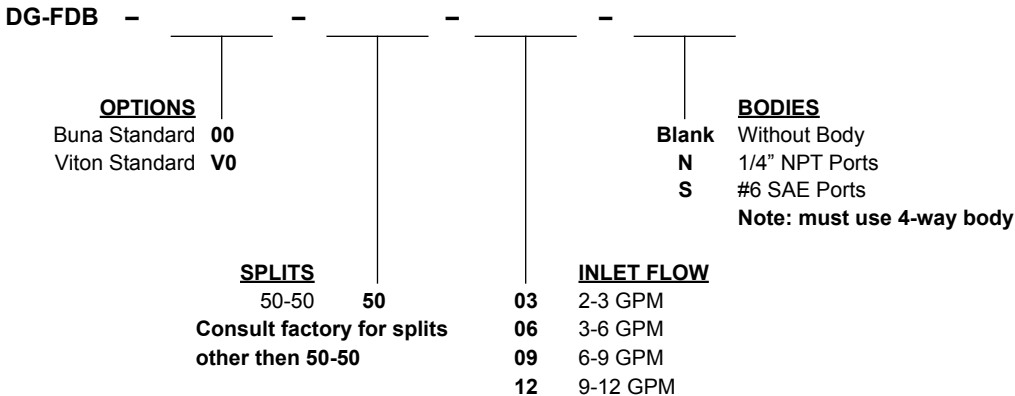

W6 / 2020

WARNING: the specifications/application data shown in our catalogs and data sheets are intended only as a general guide for the product described (herein). Any specific application should not be undertaken without independent study, evaluation, and testing for suitability.



4484 Boeing Drive Rockford, IL 61109 • USA • Phone +1 (815) 397-6628 • Fax +1 (815) 397-2526
 mail: delta@delta-power.com • www.delta-power.com



Via Malavolti, 36 • 41122 Modena • ITALY • Phone +39 (059) 254895 • Fax +39 (059) 253512
 mail: tecnord@tecnord.com • www.tecnord.com