

Features

- Non-SAE 4-bolt mounting
- Deep Groove Ball Bearings
- May be either Face-mounted or Foot-mounted
- Provides a sturdy mounting base for the motor or pump
- Supports heavy radial and axial loads - protecting the hydraulic motor or pump
- Reduces downtime and maintenance costs
- Protects pump or motor shaft seal from harmful contaminants

415 Series Data

Input Standard	Non-SAE 4-bolt mount (designed to fit a popular LSHT Geroler motor)
Input Pilot Diameter	1.750"
Input Pilot Depth	0.125"
Input Pilot Sealing Method	Fiber Gasket
Input Bore Diameter and Depth	1" keyed - bore depth is 2.18"
Output Shaft Diameter	1-1/2"
Output Shaft Keyway	3/8" x 3/16" keyway
Output Shaft Keyway Length	2.06"
Output Shaft Length	2.87"
Output Pilot Diameter	2.500"
Output Pilot Height	0.125"
Shaft Material	1144 Stressproof Steel
Bearing Type	Deep Groove Ball Bearings
Standard Lubrication Method	Grease
Optional Lubrication Methods	Please Consult Factory
Grease Fitting	(1) Standard Zerk Fitting
Grease Capacity	Minimum 0.4 oz. Maximum 1.0 oz.
Grease Type (recommended for typical applications)	NLGI #2
Recommended Grease Base	Lithium
Standard Mounting Orientation	Shaft Horizontal - Consult Factory for other Mounting Orientations
Maximum Speed Without Modification	3800 RPM
Housing Material	Cast Iron
Housing Feet - Threaded Holes	(4) 3/8"-16 UNC x 0.68" deep
Housing Grease Ports	Press-fit Zerk Fitting
Unit Weight	10 lbs

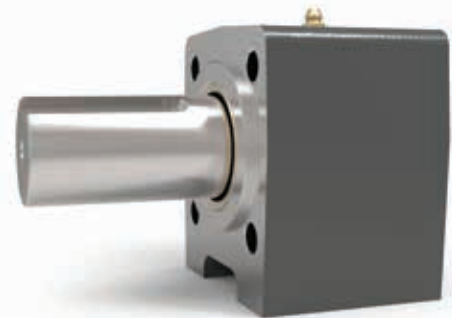

Input End View

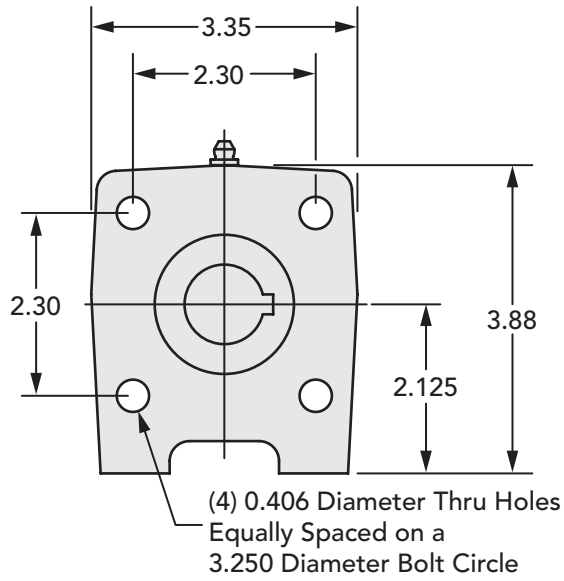

Side View

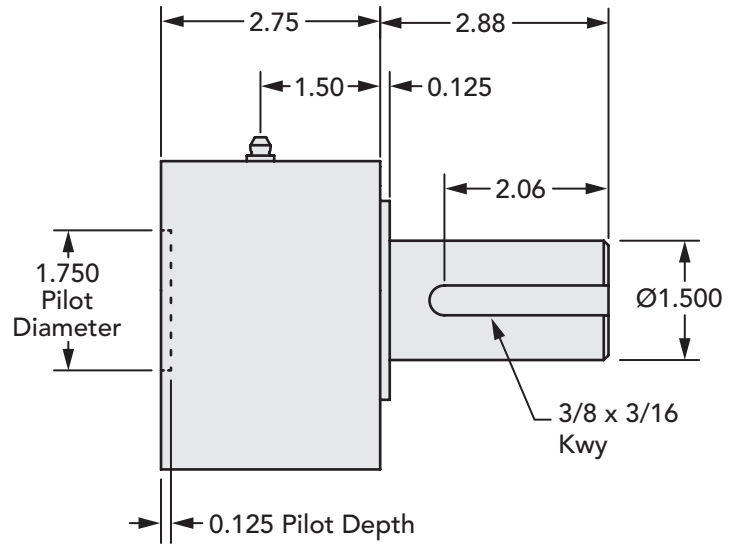

Bottom View

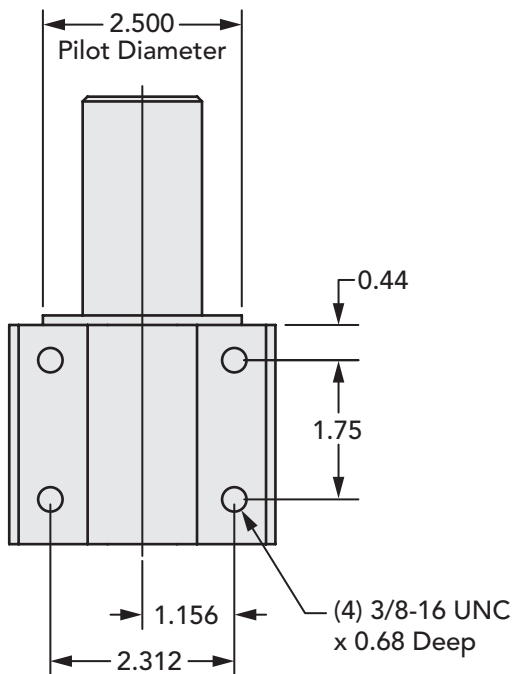

How to Order

Standard 415 Series Models		
Part Number	Output Shaft - Keyway	Input Bore - Keyway
415	1-1/2" - 3/8 x 3/16	1" - 1/4 x 1/8



Overhung Load Adaptor (OHLA)

Standard Units ■ Grease Lubricated ■ Horizontal Mounting



OHLA Lubrication and Operation Guide

This Lubrication and Operation Guide applies to standard, grease lubricated OHLA units only. Special OHLAs or unique operating conditions should be discussed directly with the factory.

GREASE CAPACITY

Grease Capacity for Standard OHLAs (Horizontal Mounting*)			
OHLA Series	SAE Mount	MIN. (oz)	MAX. (oz)
200	A	0.5	1.0
300	A	0.7	1.4
350**	A (2-bolt + Magneto)	0.6**	1.1**
400	-	0.4	1.0
500	A (Magneto)	2.0	4.0
600	B	2.2	4.4
650**	B	1.75**	3.5**
800	C	2.8	5.6
900	C	4.3	8.6
950**	C	3.4**	6.8**
1100**	D	10**	15**
1250	E	11	22
1500	F	11	22

** PER GREASE FITTING (2 fittings on 350/650/950/1100 OHLAs)

- Above listed fill amounts are for empty units. Under-lubricating or exceeding the maximum grease capacity can result in overheating of the bearing and reduced operating life.
- It is recommended to apply grease to the OHLA input bore connection to reduce wear and maximize life.

GREASE TYPE

Grease Type for Standard OHLAs (Horizontal Mounting*)	
Indoor	Lithium Base NLGI #1 or NLGI #2
Outdoor	Lithium Base NLGI #1 or NLGI #2 (Synthetic recommended)
Severe/Food Grade	Consult Zero-Max to determine if special grease is needed

- Standard OHLA units are designed and configured for grease lubrication (0-7 PSI) and operation between -40°F to 212°F (-40°C to 100°C).
- Make sure grease used meets temperature requirements of the application.
- Contact the factory to discuss critical considerations and options if other lubrication methods are being considered or for conditions outside of these pressure/temperature ranges.

RPM RATING

RPM Rating for Standard OHLAs (Horizontal Mounting*)			
OHLA Series	SAE Mount	Bolt Type	RPM Rating (without modification)
200	A	2	3800
300	A	2	3100
350	A (2-bolt + Magneto)	2/4/6	3300
400	-	4	3800
500	A (Magneto)	2/4	2300
600	B	2/4	2300
650	B	2/4	3500
800	C	2/4	2300
900	C	2/4	1900
950	C	2/4	2500
1100	D	2/4	2500
1250	E	4	1500
1500	F	4	1500

- Above listed RPM values are guidelines for standard units that are properly grease lubricated and running under typical conditions.
- Many factors can influence the maximum RPM in a specific application. Contact factory with specifics on your application or as speeds approach the maximum values listed here.

*VERTICAL OHLA APPLICATIONS

- Standard OHLAs are configured for horizontal mounting (shaft parallel with the ground). For applications where the OHLA shaft will be vertical, or on an incline, please contact Zero-Max to discuss the ideal configuration of a unit (bearings, seals, shafts, etc.) for your application.
- Configuration and ratings of most OHLAs change when the mounting orientation is altered.

OHLA RATINGS/LIFE EXPECTANCY

- The estimated life for an OHLA is typically measured in bearing hours (L10_n) and depends on many factors such as Horsepower (HP), Speed (RPM), Loading, Bearings, Lubrication, Environment, and more.
- It is recommended to contact Zero-Max with your application specifications so an accurate L10_n bearing life can be calculated. Zero-Max Engineering can offer customization options to improve OHLA life expectancy in many applications if a standard unit will not suffice.