

DF-CPB PILOT OPERATED CHECK VALVE, GUIDED BALL

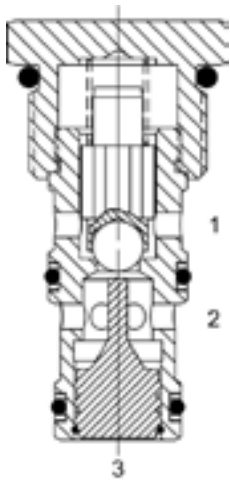

DESCRIPTION

10 size, 7/8-14 thread, "Delta" series, pilot operated, ball check valve.

OPERATION

The DF-CPB allows free flow to pass from (2) to (1) and blocks flow from (1) to (2). When pilot pressure is applied to port (3) the valve allows free flow from (1) to (2).

FEATURES

- Hardened parts for long life.
- Industry common cavity.

HYDRAULIC SYMBOL

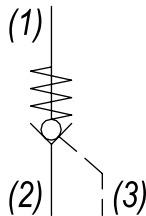

For sealed pilot piston consult factory.
0.030" to 0.060" diameter orifice recommended in the feed line to port #3.

PERFORMANCE

Actual Test Data (Cartridge Only)

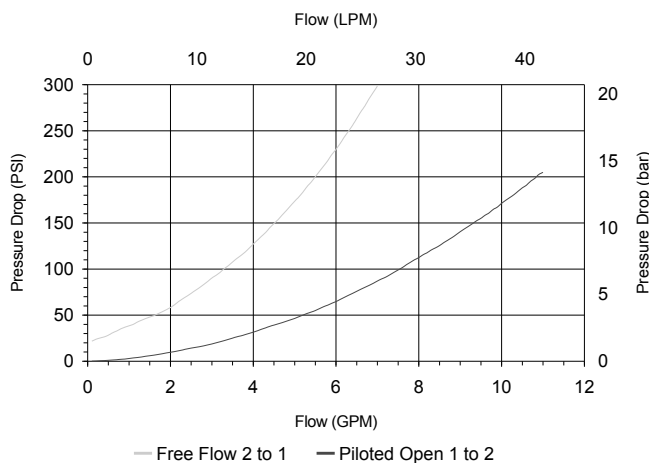

VALVE SPECIFICATIONS

Nominal Flow	8 GPM (30 LTR/M) from (1) to (2) 5 GPM (19 LTR/M) from (2) to (1)
Rated Operating Pressure	3500 PSI (241 bar)
Typical Internal Leakage (150 SSU)	0-5 drops/min
Pilot Ratio	4:1
Viscosity Range	36 to 3000 SSU (3 to 647 cSt)
Filtration	ISO 18/16/13
Media Operating Temp. Range	-40° to 250°F (-40° to 120°C)
Weight	.19 lbs (.09 kg)
Operating Fluid Media	General Purpose Hydraulic Fluid
Cartridge Torque Requirements	30 ft-lbs (40.6 Nm)
Cavity	DELTA 3W
Cavity Form Tool (Finishing)	40500001
Seal Kit	21191202

WARNING: the specifications/application data shown in our catalogs and data sheets are intended only as a general guide for the product described (herein). Any specific application should not be undertaken without independent study, evaluation, and testing for suitability.



4484 Boeing Drive Rockford, IL 61109 • USA • Phone +1 (815) 397-6628 • Fax +1 (815) 397-2526
mail: delta@delta-power.com • www.delta-power.com



Via Malavolti, 36 • 41122 Modena • ITALY • Phone +39 (059) 254895 • Fax +39 (059) 253512
mail: tecnord@tecnord.com • www.tecnord.com

DIMENSIONS

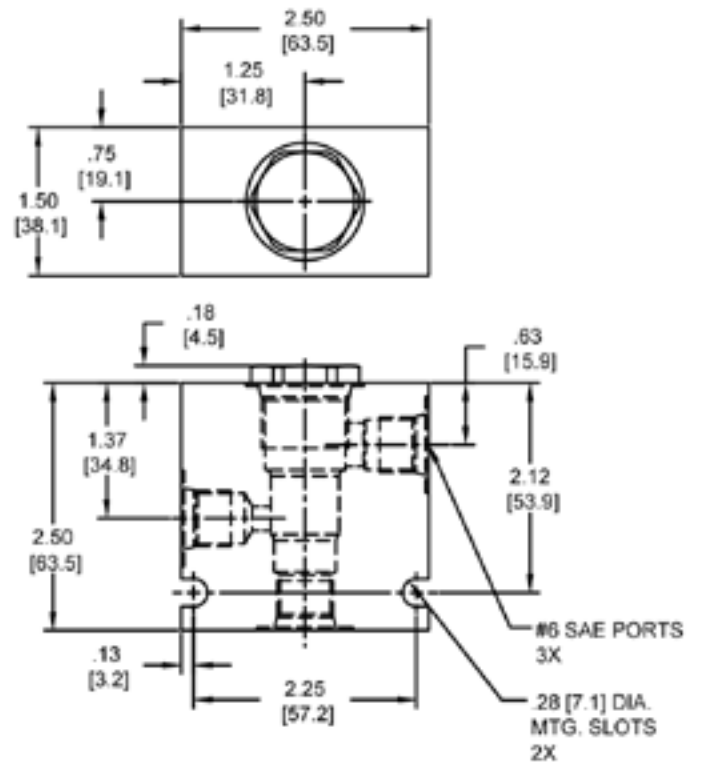
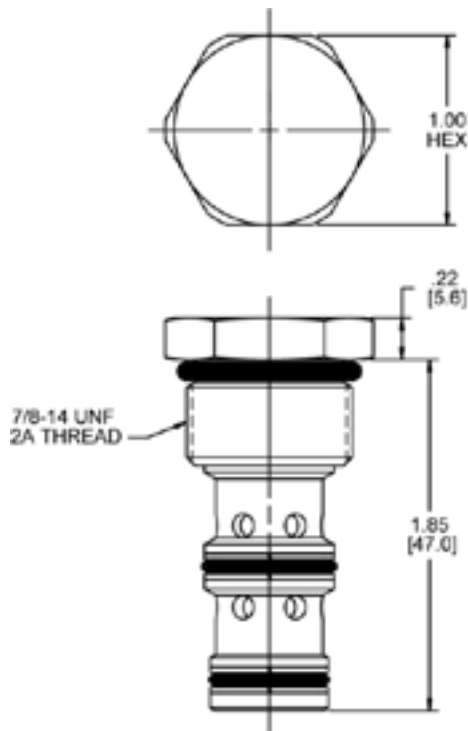

ORDERING INFORMATION

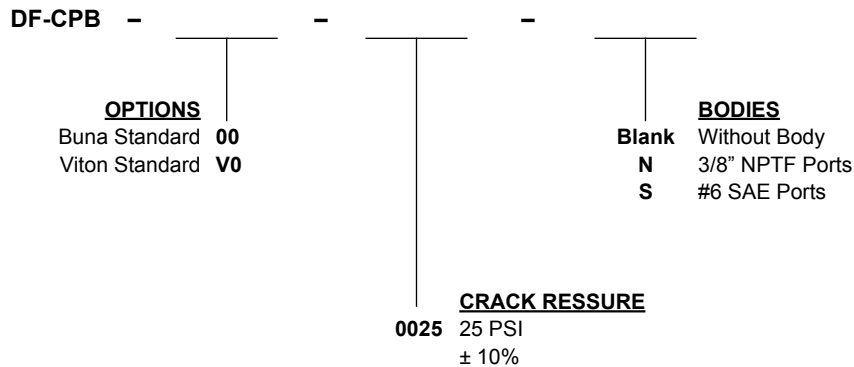

W 40 / 2018

WARNING: the specifications/application data shown in our catalogs and data sheets are intended only as a general guide for the product described (herein). Any specific application should not be undertaken without independent study, evaluation, and testing for suitability.



4484 Boeing Drive Rockford, IL 61109 • USA • Phone +1 (815) 397-6628 • Fax +1 (815) 397-2526
mail: delta@delta-power.com • www.delta-power.com



Via Malavolti, 36 • 41122 Modena • ITALY • Phone +39 (059) 254895 • Fax +39 (059) 253512
mail: tecnord@tecnord.com • www.tecnord.com