

**DG-FDH FLOW DIVIDER / COMBINER VALVE, SPOOL TYPE**

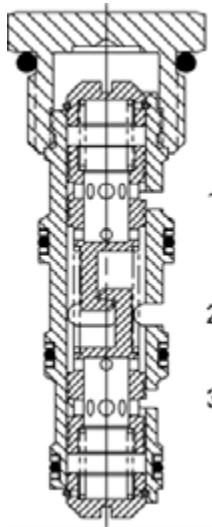

**DESCRIPTION**

“High Accuracy” 10 size, 7/8-14 thread “Delta Series”, spool type, flow divider/combiner.

**OPERATION**

In the dividing mode, the DG-FDH will divert input flow from port (2) to ports (3) and (1), based on the ratio specified with a high degree of accuracy, regardless of operating pressure. The DG-FDH will combine input flows from ports (3) and (1), to port (2) by the same ratio. Should circuit operation result in a blockage of either (3) or (1), the opposite port may also close under certain conditions. Should this potential exist, consult the factory.

**FEATURES**

- Hardened parts for long life.
- Industry common cavity.



*DO NOT EXCEED MAXIMUM FLOW PER MODEL. The DG-FDH should be considered if the DG-FDA does not provide the required accuracy.*

**HYDRAULIC SYMBOL**

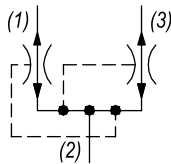

**PERFORMANCE**

Actual Test Data (Cartridge Only)

**VALVE SPECIFICATIONS**

Maximum Flow	12 GPM (45 LPM)
Accuracy on Flow Splits	±4% of Max Rated Inlet Flow
Maximum Operating Pressure	3500 PSI (241 bar)
Viscosity Range	36 to 3000 SSU (3 to 647 cSt)
Filtration	ISO 18/16/13
Media Operating Temp. Range	-40° to 250°F (-40° to 120°C)
Weight	.21 lbs (.10 kg)
Operating Fluid Media	General Purpose Hydraulic Fluid
Cartridge Torque Requirements	30 ft-lbs (40.6 Nm)
Cavity	DELTA 4W
Cavity Form Tool (Finishing)	40500002
Seal Kit	21191214

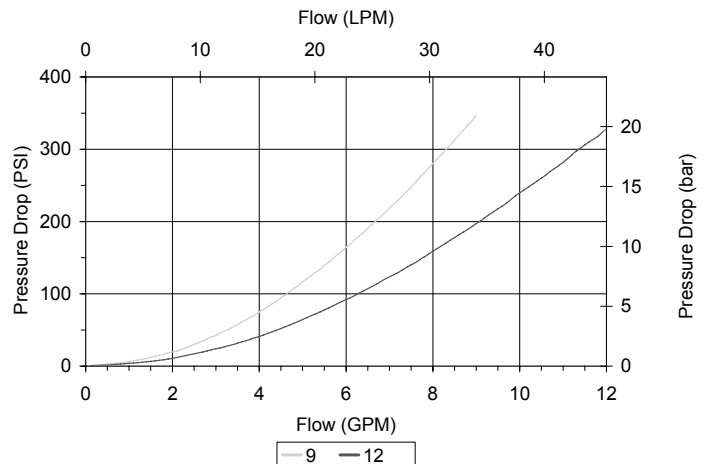
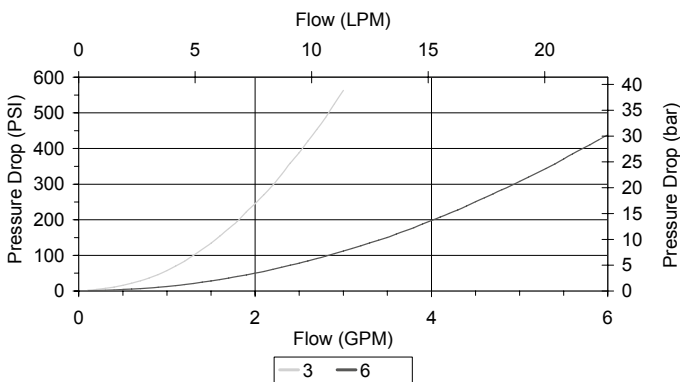

**WARNING:** the specifications/application data shown in our catalogs and data sheets are intended only as a general guide for the product described (herein). Any specific application should not be undertaken without independent study, evaluation, and testing for suitability.



4484 Boeing Drive Rockford, IL 61109 • USA • Phone +1 (815) 397-6628 • Fax +1 (815) 397-2526  
 mail: delta@delta-power.com • www.delta-power.com



Via Malavolti, 36 • 41122 Modena • ITALY • Phone +39 (059) 254895 • Fax +39 (059) 253512  
 mail: tecnord@tecnord.com • www.tecnord.com

**DIMENSIONS**

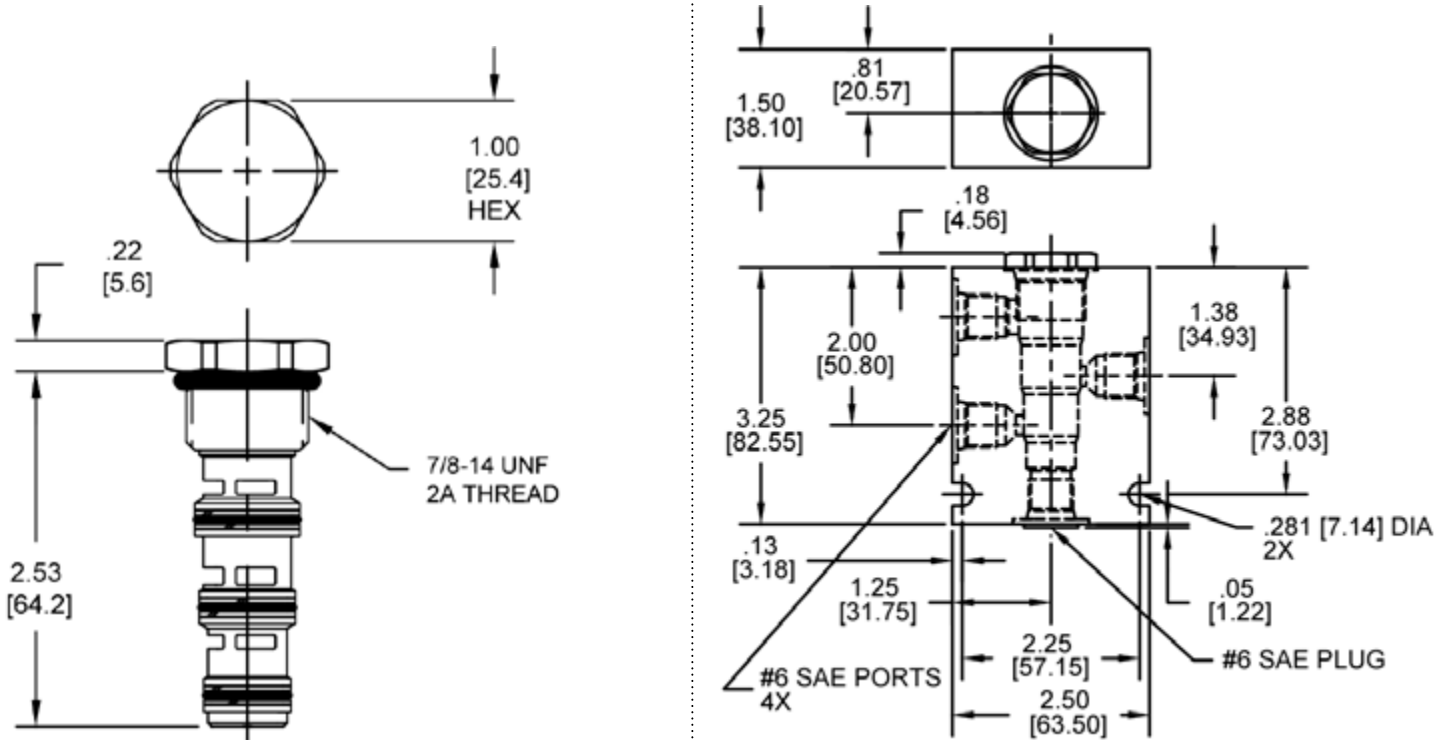

Body Weight: .99 lbs (.45 kg)

**ORDERING INFORMATION**

<b>DG-FDH</b> -		-	-	-	-	-
<b>OPTIONS</b>						
Buna Standard	00					
Viton Standard	V0					
<b>SPLITS</b>						
50-50	50					
Consult factory for splits other than 50-50						
<b>INLET FLOW</b>						
03	2-3 GPM					
06	3-6 GPM					
09	6-9 GPM					
12	9-12 GPM					
<b>BODIES</b>						
Blank	Without Body					
N	1/4" NPT Ports					
S	#6 SAE Ports					
Note: must use 4-way body						

W 15 / 2017

**WARNING:** the specifications/application data shown in our catalogs and data sheets are intended only as a general guide for the product described (herein). Any specific application should not be undertaken without independent study, evaluation, and testing for suitability.



4484 Boeing Drive Rockford, IL 61109 • USA • Phone +1 (815) 397-6628 • Fax +1 (815) 397-2526  
 mail: delta@delta-power.com • www.delta-power.com



Via Malavolti, 36 • 41122 Modena • ITALY • Phone +39 (059) 254895 • Fax +39 (059) 253512  
 mail: tecnord@tecnord.com • www.tecnord.com