

## INDEX

<u>Description</u>	<u>Page</u>
Delta Power Rotary Flow Divider, Positive Displacement ( <i>Application Data</i> )	36
P Series, Equal Flow Two Sections	39
P Series, Equal Flow Multi-Sections	40
PM Series, Equal Flow Multi-Sections	41
PM Series, Mixed Flow Buildable	42
P Series, Mixed Flow Buildable	43
PM Series, Equal Flow Multi-Section with Relief Valves	44
HPR Series, Heavy Duty with Relief Valves	45

**WARNING:** The specifications/application data shown in our catalogs and data sheets are intended only as a general guide for the product described (herein). Any specific application should not be undertaken without independent study, evaluation, and testing for suitability.

*Delta Power Rotary Flow Divider, Positive Displacement*

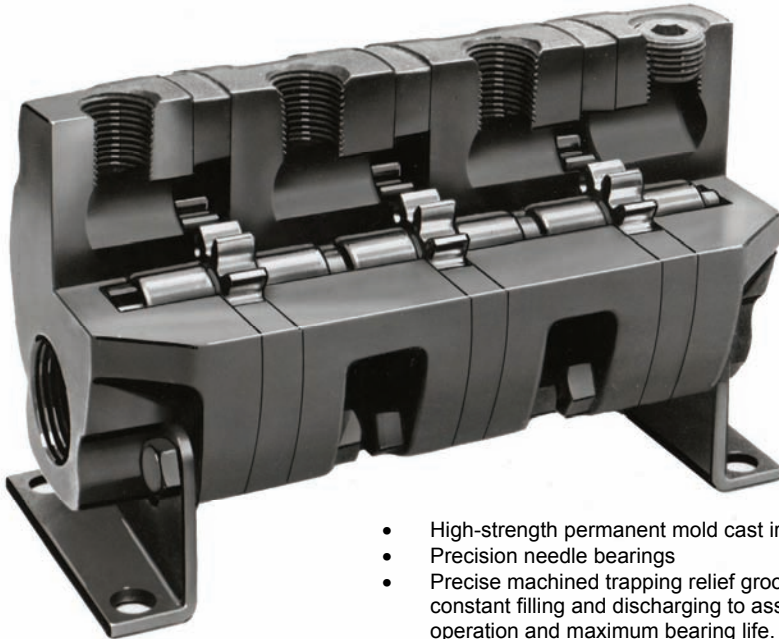

- High-strength permanent mold cast iron housing
- Precision needle bearings
- Precise machined trapping relief grooves provide constant filling and discharging to assure quiet operation and maximum bearing life.
- O-ring seals between sections (Buna-N)

Delta Series P geared flow dividers, accurately divide flow from a single hydraulic source into two or more equal or *proportionate* circuits. In like manner, the input pressure required will be proportional to levels of flow/pressure out of the flow divider, rather than at the highest pressure level, thereby saving what would normally be wasted energy. Proven design, stable material selection and precision machining are the Delta keys to reliable performance you can depend on in a variety of applications.

**Application Suggestions**

1. For greatest efficiency and accuracy, flow dividers should be used at near maximum rated inlet gallonage. For quieter operations, lowered RPM should be considered.
2. Maximum (3500) and minimum 500 RPM; inlet pressure ratings and differential pressure ratings should be followed.
3. Provide over-pressure protection (relief valves) in each circuit.
4. When designing flow dividers into a static circuit, remember that they are *dynamic* devices which do nothing while static.
5. Use SAE 10 through SAE 30 industrial petroleum-based hydraulic oil with 200 SSU viscosity; filter to 25 microns.
6. Do not use teflon tape in installation. Use plastic pipe sealant with NPTF ports.

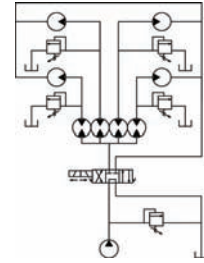

Where one pump operates a number of hydraulic motors: car wash systems lubrication systems (multiple point), hydraulic motor driven machines, (harvesting machinery, etc.)

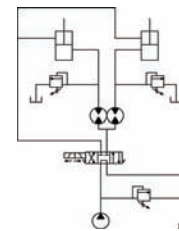

Where two or more cylinders must be synchronized: lift platforms, scaffolds, presses.

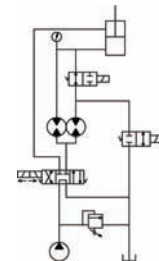

Where main pump pressure must be intensified in one circuit of multiple circuit machinery, such as waste compactors and other hi-lo applications.

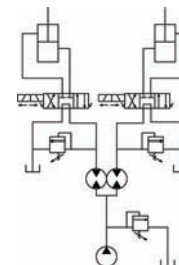

Where two or more circuits must be controlled independently at different pressures: presses, machine tools, etc.

**WARNING:** The specifications/application data shown in our catalogs and data sheets are intended only as a general guide for the product described (herein). Any specific application should not be undertaken without independent study, evaluation, and testing for suitability.

**Application Data**

The Delta flow divider is a positive displacement flow dividing or proportioning apparatus. It will divide the flow from one source into two or more equal or proportionate circuits, and intensify or reduce the pressure level as required. Note that these flow dividers will operate in reverse in a combine mode, but in that mode, the accuracy likely would be significantly reduced.

In its basic configuration, the unit consists of a number of inter coupled gear type hydraulic pump motors. Each section must be capable of performing the pumping or motoring function. The section have a common inlet and separate outlets. Fluid from a prime source, such as pump, supplies the motive power to the flow divider. No energy is added to the fluid in the device, although each outlet may have an energy level difference than any other section. When the sections are of like size, the function is to divide the total flow into equal increments of flow, and when the sections are of unlike size, the function is to divide the flow into proportionate increments relative to the chosen geometric displacements.

Since the flow divider is a positive displacement machine, it will accomplish its function over a wide range of pressure of viscosity differentials. Nevertheless, certain limits are imposed due to slip characteristics and torque losses in the machine. Therefore, the performance criteria in this paper will be developed around a unit of average tolerance allowance. The data, so derived, will be averaged. Be aware that these units can require a certain amount of break-away pressure. It is recommended that operation at low pressures (< 100 PSI) is not attempted without consultation with the factory.

**General Relationships**

In any unit, neglecting any losses, there exists the relationship that

$$Q_i = Q_1 + Q_2 + \dots Q_n;$$

Where  $Q_i$  is the flow into the unit and  $Q_1$ ,  $Q_2$  and  $Q_n$  are the displacements out of each section. Since no energy is added and if none were lost, it follows that

$$P_i Q_i = P_1 Q_1 + P_2 Q_2 + \dots P_n Q_n;$$

Where  $P_i$  is the pressure into the unit and  $P_1$ ,  $P_2$  and  $P_n$  are the pressure levels out of each section.

In a unit consisting of any number of/or sizes of sections

$$P_i = \frac{P_1 Q_1 + P_2 Q_2 + \dots P_n Q_n}{Q_i}$$

In any actual case, the above theoretical observations must be corrected to encompass the pressure drop and slip losses in the flow divider. The pressure drop is primarily a function of the amount of fluid and viscosity. At the usual viscosities (100 to 300 SSU) encountered in hydraulic systems, the pressure drop  $\Delta P_p$ , can be approximated by the relationship, where n is the number of sections,

$$\Delta P_p \cong \frac{6Q_i}{n} + 25$$

Since the flow divider itself is a parallel circuit, the actual pressure  $P_{ia}$  into the unit is

$$P_{ia} \cong \frac{P_1 Q_1 + P_2 Q_2 + \dots P_n Q_n}{Q_i} + \Delta P_p$$

**WARNING:** The specifications/application data shown in our catalogs and data sheets are intended only as a general guide for the product described (herein). Any specific application should not be undertaken without independent study, evaluation, and testing for suitability.

Slip is a function of the viscosity, pressure differential and clearance and can be estimated from the following chart:

<u>Model</u>	<u>Displacement Gal./Rev./Sect.</u>	<u>Slip/100 PSI (GPM)</u>	<u>Max. Flow/Sect. (GPM)</u>
PM2	.00047	.03	2.0
PM6	.00137	.04	5.5
P21	.00178	.06	7.6
P23	.00304	.07	12
P25	.00425	.08	17
P26	.00531	.10	20
P27	.00633	.11	25
P43	.01020	.15	35
P47	.01690	.22	50

The slip function increases or decreases the flow from a section, dependent on whether the pressure differential is positive or negative across that section.

The performance of a system would be determined in the following manner.

1. Determine the size of the sections that will best give the required flow and pressure. The displacement from each section will be the fractional proportion of the sectional displacement versus the sum of the displacements of all the sections. That fraction multiplied by the input flow gives output displaced by each section.

2. Determine  $\Delta P_p$  from  $\Delta P_p \cong \frac{6Q_i}{n} + 25$

3. Determine  $P_{ia}$  from  $P_{ia} \cong \frac{P_1 Q_1 + P_2 Q_2 \dots P_n Q_n}{Q_1} + \Delta P_p$

4. Determine the pressure differential  $\Delta P_1, \Delta P_2, \Delta P_n$  across the individual section where  $\Delta P_1 = \Delta P_{ia} - \Delta P_1$ , etc., and from this value, determine the slips  $S_1, S_2, S_n$ .

5. Determine  $Q_{1a}, Q_{2a}, Q_{na}$  from  $Q_{1a} = Q_1 + S_1$ , etc.

The foregoing description is intended as an aid in determining the results of a flow divider system. Any specific application should not be undertaken without independent study, evaluation and testing for suitability. Exceeding the specifications could result in equipment malfunction, property damage, serious injury or death.

**WARNING:** The specifications/application data shown in our catalogs and data sheets are intended only as a general guide for the product described (herein). Any specific application should not be undertaken without independent study, evaluation, and testing for suitability.

*P Series, Equal Flow Two Sections*

Equal flow two-section units divide flow from a common pump source into separate flows of equal proportion. Both gear sets are assembled to a common shaft.

**PM2 & PM6**

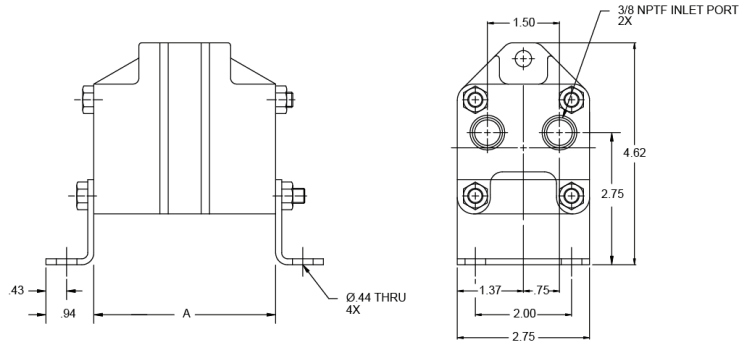

**P23 & P27**

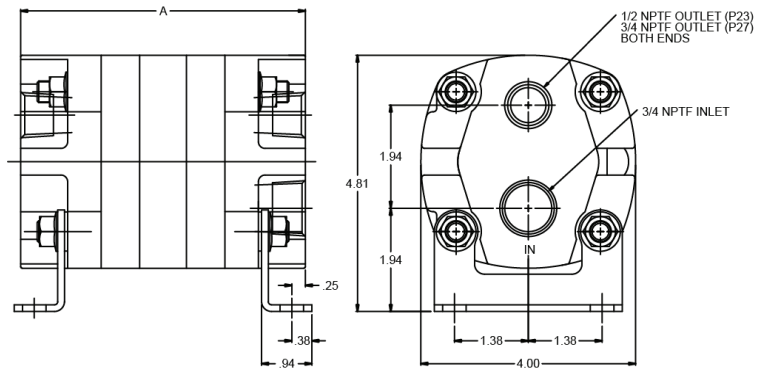

**P43 & P47**

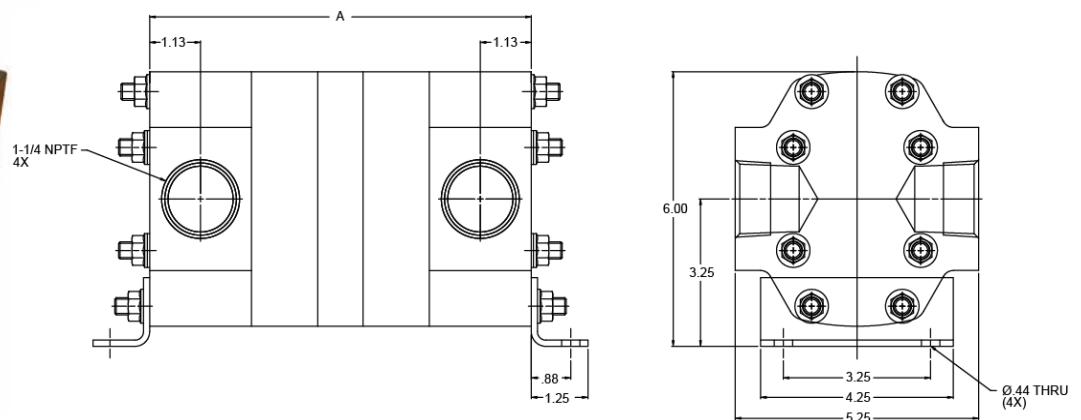

MODEL	NUMBER OF SECTIONS	TOTAL MAX. INLET (GPM)	0 PSI DISP. PER SECT. GAL./REV.	SLIP GPM/100 PSI	MAXIMUM INTERMITTENT PSI	MAXIMUM CONTINUOUS PSI	BOLT TORQUE Ft. Lb.	A	MAX. DIFF. BETWEEN SECT. (PSI)
PM2	2	3.5	0.00047	0.026	2500	2000	13-17	3.83	1500
PM6	2	9.5	0.00137	0.038	2000	1500	13-17	4.72	1000
P23	2	21.0	0.00304	0.068	2000	1500	24-31	5.32	1000
P27	2	44.0	0.00633	0.113	2000	1500	24-31	6.86	1000
P43	2	70.0	0.01020	0.135	2000	1500	24-31	7.75	1000
P47	2	100.0	0.01690	0.210	2000	1500	24-31	9.25	1000

**WARNING:** The specifications/application data shown in our catalogs and data sheets are intended only as a general guide for the product described (herein). Any specific application should not be undertaken without independent study, evaluation, and testing for suitability.



**P Series, Equal Flow Multi-Sections**

Equal flow multi-section units consist of several identical, individual sections coupled together to divide a flow from a common pump source into three or more equal flows. Each set of gear and shaft assemblies are individually supported in needle bearings.

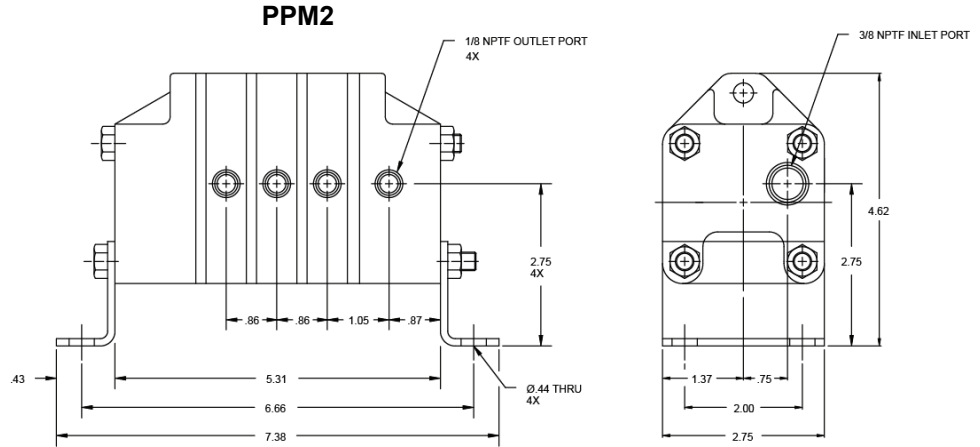

**P23-(57-60) & P27-(57-60)**

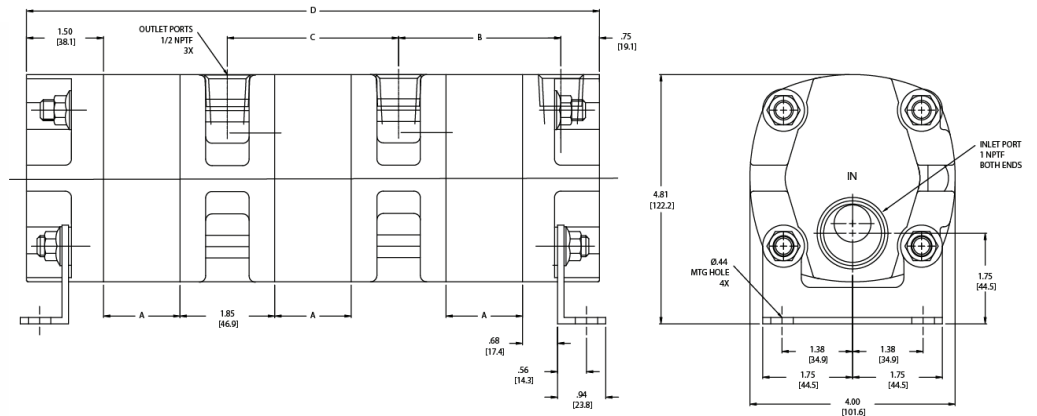

MODEL	NUMBER OF SECTIONS	TOTAL MAX. INLET (GPM)	0 PSI DISP. PER SECT. GAL./REV.	SLIP GPM/100 PSI	MAXIMUM INTERMITTENT PSI	MAXIMUM CONTINUOUS PSI	BOLT TORQUE Ft. Lb.	A	B	C	D	MAX. DIFF. BETWEEN SECT. (PSI)
PPM2	4	7.0	0.00047	0.026	2000	1500	13-17	-	-	-	-	1000
P23-60	3	31.5	0.00304	0.068	2000	1500	24-31	0.715	2.39	2.56	8.83	1000
P23-59	4	42.0	0.00304	0.068	2000	1500	24-31	0.715	2.39	2.56	11.39	1000
P23-58	5	52.5	0.00304	0.068	2000	1500	24-31	0.715	2.39	2.56	13.95	1000
P23-57	6	63.0	0.00304	0.068	2000	1500	24-31	0.715	2.39	2.56	16.51	1000
P27-60	3	66.0	0.00633	0.113	2000	1500	24-31	1.490	3.16	3.33	11.16	1000
P27-59	4	88.0	0.00633	0.113	2000	1500	24-31	1.490	3.16	3.33	14.49	1000
P27-58	5	110.0	0.00633	0.113	2000	1500	24-31	1.490	3.16	3.33	17.82	1000
P27-57	6	132.0	0.00633	0.113	2000	1500	24-31	1.490	3.16	3.33	21.15	1000

**WARNING:** The specifications/application data shown in our catalogs and data sheets are intended only as a general guide for the product described (herein). Any specific application should not be undertaken without independent study, evaluation, and testing for suitability.

**PM Series, Equal Flow Multi-Sections**

Equal flow multi-section units consist of several identical, individual sections coupled together to divide a flow from a common pump source into three or more equal flows. Each set of gear and shaft assemblies are individually supported in needle bearings.

**PM2**

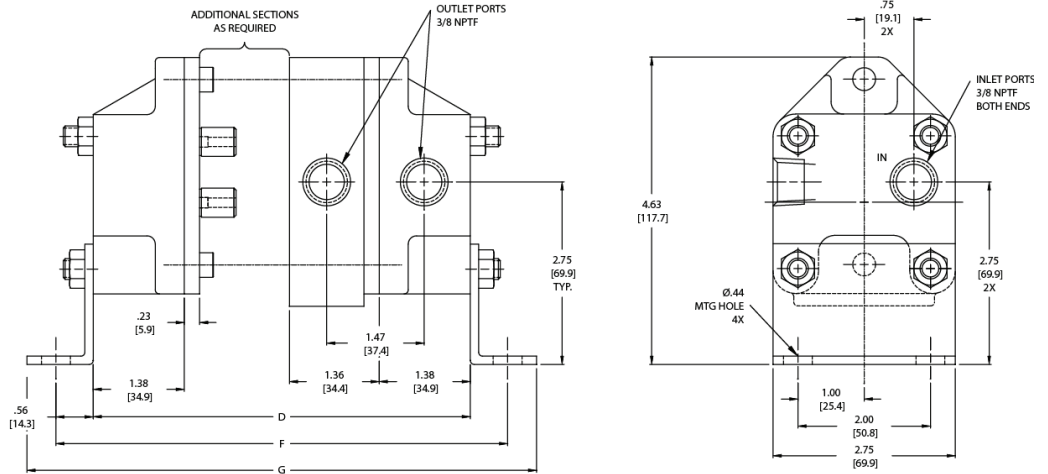

**PM6**

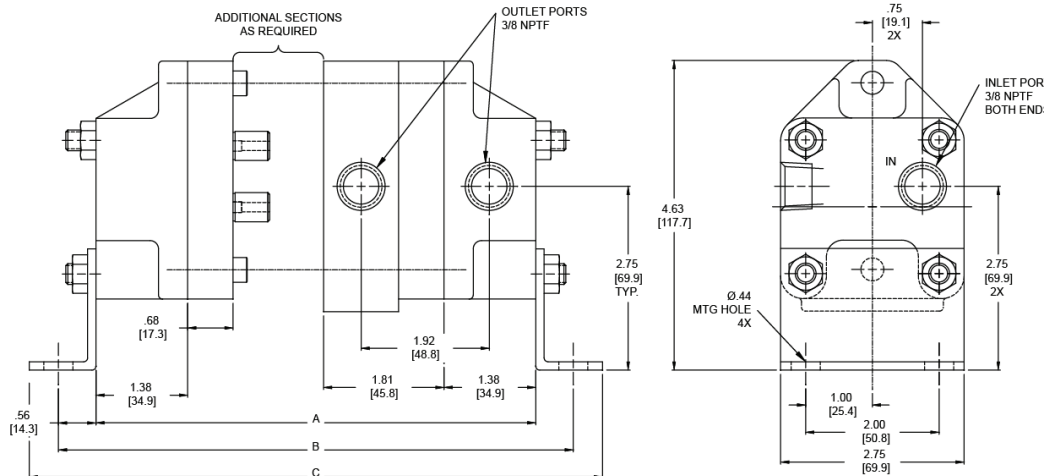

MODEL	NUMBER OF SECTIONS	TOTAL MAX. INLET (GPM)	0 PSI DISP. PER SECT. GAL./REV.	SLIP GPM/100 PSI	MAXIMUM INTERMITTENT PSI	MAXIMUM CONTINUOUS PSI	BOLT TORQUE Ft. Lb.	A	B	C	MAX. DIFF. BETWEEN SECT. (PSI)
PM2-60	3	5.3	0.00047	0.017	2500	2000	24-31	5.71	6.83	7.71	1000
PM2-59	4	7.0	0.00047	0.017	2500	2000	24-31	7.07	8.19	9.07	1000
PM2-58	5	8.8	0.00047	0.017	2500	2000	24-31	8.43	9.55	10.43	1000
PM2-57	6	10.5	0.00047	0.017	2500	2000	24-31	9.79	10.91	11.79	1000
PM6-60	3	14.3	0.00137	0.025	2000	1500	24-31	7.06	8.18	9.06	1000
PM6-59	4	19.0	0.00137	0.025	2000	1500	24-31	8.87	9.99	10.87	1000
PM6-58	5	23.8	0.00137	0.025	2000	1500	24-31	10.68	11.80	12.68	1000
PM6-57	6	28.5	0.00137	0.025	2000	1500	24-31	12.49	13.51	14.49	1000

Additional equal-flow units (up to 6 sections) may be built up using several of the same section as shown in the Mixed Flow Chart.  
 Note: When computing slip loss, above figures should be applied to reflect differential pressure between inlet and outlet of each section. Due to normal manufacturing tolerances, accuracies can be assumed to be no greater than +/- 1% between sections under balanced load conditions.

**WARNING:** The specifications/application data shown in our catalogs and data sheets are intended only as a general guide for the product described (herein). Any specific application should not be undertaken without independent study, evaluation, and testing for suitability.

**PM Series, Mixed Flow Buildable**

Mixed flow dividers are “built-up” in any combination (up to 8) from the individual sections shown in the following chart to divide flow from a common pump source into a variety of proportionate flows. Each set of gear and shaft assemblies are individually supported in needle bearings.

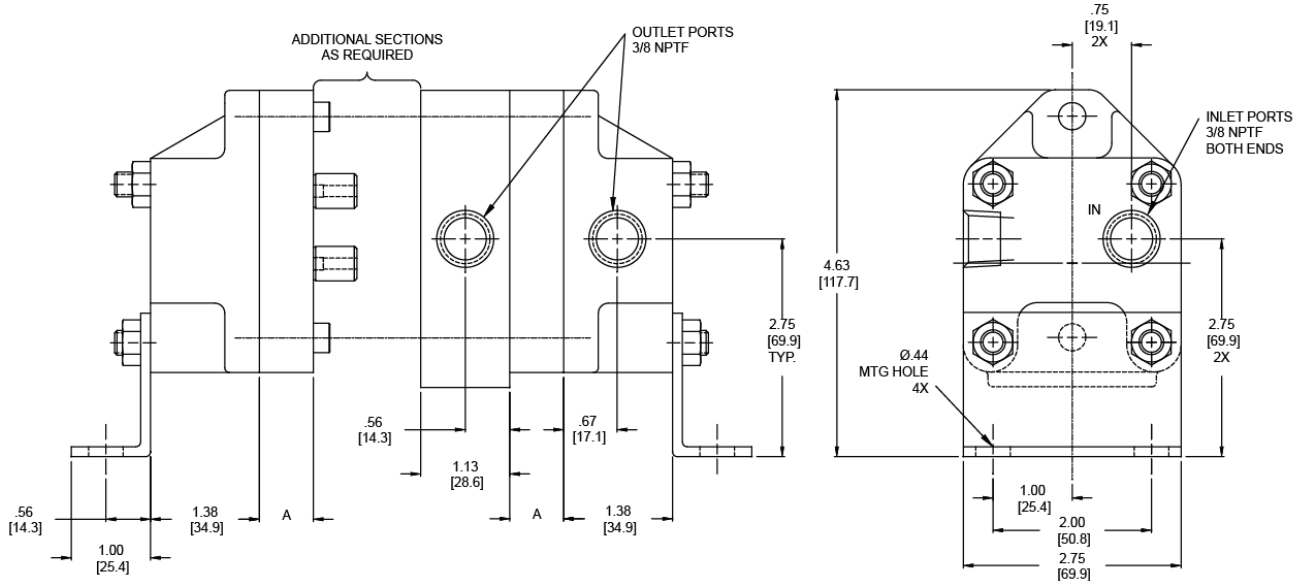

MODEL	NUMBER OF SECTIONS	TOTAL MAX. INLET (GPM)	0 PSI DISP. PER SECT. GAL./REV.	SLIP GPM/100 PSI	MAXIMUM INTERMITTENT PSI	MAXIMUM CONTINUOUS PSI	BOLT TORQUE Ft.-Lb.	MAX. DIFF. BETWEEN SECT. (PSI)	MAXIMUM RPM	MINIMUM RPM	A
PM1	1	1.0	0.00028	0.015	2500	2000	24-31	1000	3500	500	0.14
PM2	1	1.8	0.00047	0.017	2500	2000	24-31	1000	3500	500	0.23
PM4	1	3.0	0.00081	0.020	2000	1500	24-31	1000	3500	500	0.31
PM6	1	4.8	0.00137	0.025	2000	1500	24-31	1000	3500	500	0.40
PM8	1	3.6	0.00202	0.030	2000	1500	24-31	1000	3500	500	0.53

**WARNING:** The specifications/application data shown in our catalogs and data sheets are intended only as a general guide for the product described (herein). Any specific application should not be undertaken without independent study, evaluation, and testing for suitability.

Phone: (815) 397-6628

Fax: (815) 397-2526

E-mail: [delta@delta-power.com](mailto:delta@delta-power.com)



**P Series, Mixed Flow Buildable**

Mixed flow dividers are “built-up” in any combination (up to 8) from the individual sections shown in the following chart to divide flow from a common pump source into a variety of proportionate flows. Each set of gear and shaft assemblies are individually supported in needle bearings.

**Typical Multi-Section P21-P27**

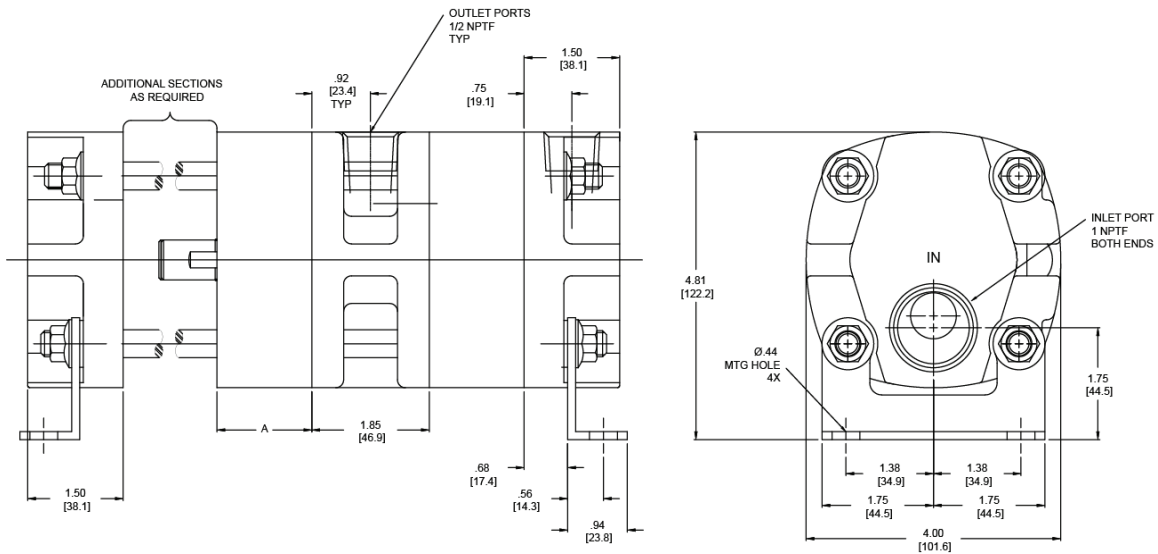

MODEL	NUMBER OF SECTIONS	TOTAL MAX. INLET (GPM)	0 PSI DISP. PER SECT. GAL./REV.	SLIP GPM/100 PSI	MAXIMUM INTERMITTENT PSI	MAXIMUM CONTINUOUS PSI	BOLT TORQUE Ft.-Lb.	MAX. DIFF. BETWEEN SECT. (PSI)	MAXIMUM RPM	MINIMUM RPM	A
P21	1	6.2	0.00178	0.060	2000	1500	24-31	1000	3500	500	0.418
P23	1	10.5	0.00304	0.068	2000	1500	24-31	1000	3500	500	0.715
P25	1	15.0	0.00425	0.083	2000	1500	24-31	1000	3500	500	1.000
P26	1	18.5	0.00531	0.098	2000	1500	24-31	1000	3500	500	1.250
P27	1	22.0	0.00633	0.113	2000	1500	24-31	1000	3500	500	1.490

For ordering purposes, a divider with two PM1 sections, one PM6 section and one PM8 section would be part number PM1-1-6-8 or a 3 section PM4 flow divider would be part number PM4-4-4

**WARNING:** The specifications/application data shown in our catalogs and data sheets are intended only as a general guide for the product described (herein). Any specific application should not be undertaken without independent study, evaluation, and testing for suitability.

**PM Series, Equal Flow Multi-Sections with Relief Valves**

Equal flow multi-section units consist of several identical, individual sections coupled together to divide a flow from a common pump source into two or more equal flows. Each set of gear and shaft assemblies are individually supported in needle bearings.

**PM2RV & PM6RV**

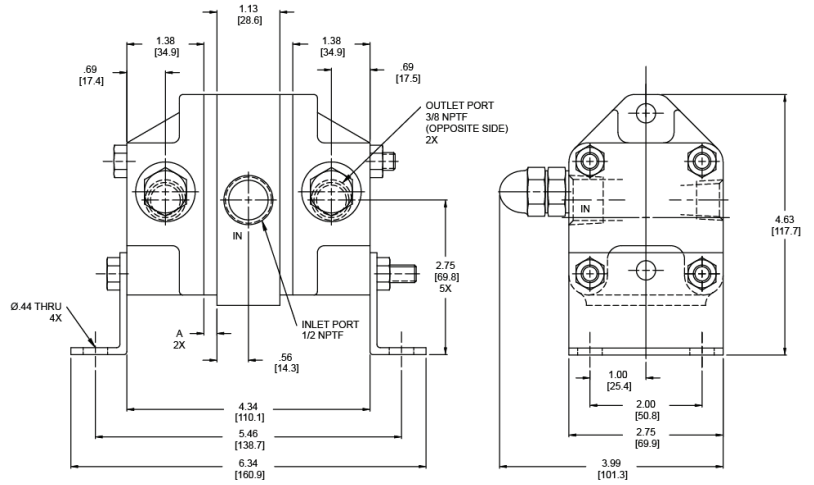
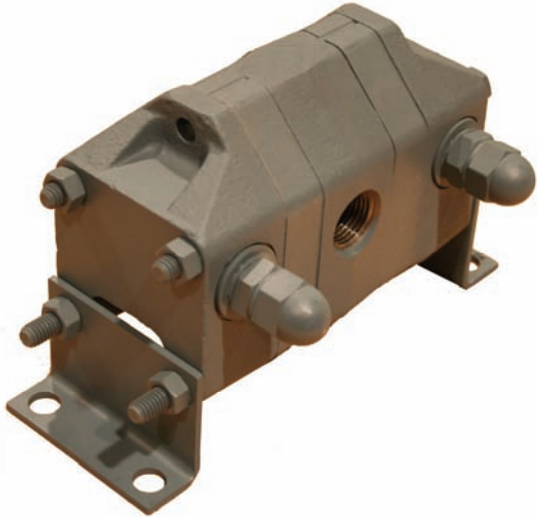

**PPM2RV**

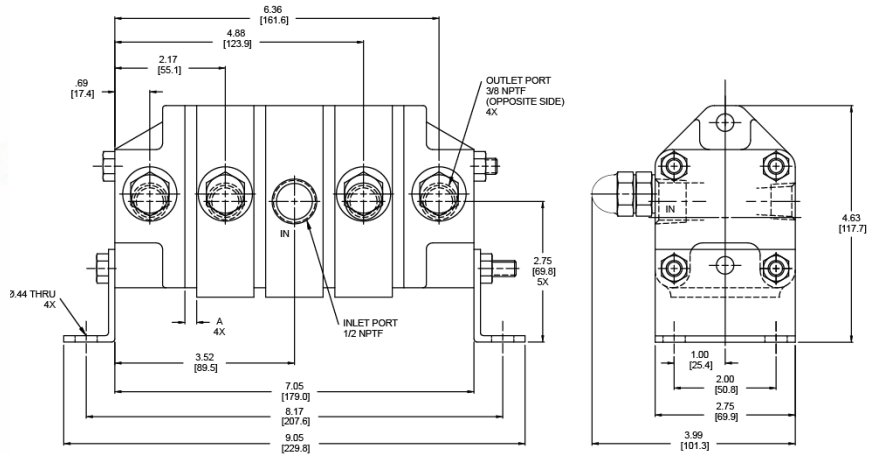
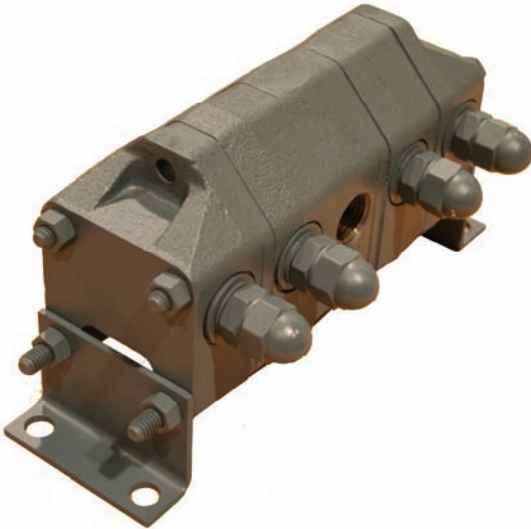

MODEL	NUMBER OF SECTIONS	TOTAL MAX. INLET (GPM)	0 PSI DISP. PER SECT. GAL./REV.	SLIP GPM/100 PSI	MAXIMUM INTERMITTENT PSI	MAXIMUM CONTINUOUS PSI	BOLT TORQUE Ft.-Lb.	MAX. DIFF. BETWEEN SECT. (PSI)	MAXIMUM RPM	MINIMUM RPM	A
PM2RV	2	3.5	0.00047	0.026	2500	2000	13-17	1500	3500	500	0.23
PM6RV	2	9.5	0.00137	0.038	2000	1500	13-17	1000	3500	500	0.40
PPM2RV	4	7.0	0.00047	0.026	2000	1500	13-17	1000	3500	500	0.53

**WARNING:** The specifications/application data shown in our catalogs and data sheets are intended only as a general guide for the product described (herein). Any specific application should not be undertaken without independent study, evaluation, and testing for suitability.

*HPR Series, Heavy Duty with Relief Valves*

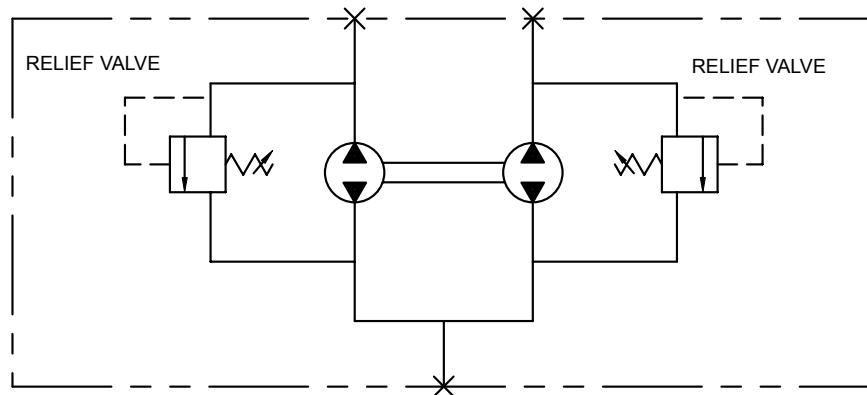

HYDRAULIC SCHEMATIC  
(TWO SECTION SHOWN)

5000 PSI (345 Bar) Intermittent Duty

3000 PSI (206 Bar) Continuous Duty *Note: HPR26-XX and HPR27-XX are 2000 PSI (137 Bar)*

3000 PSI Delta P between Sections, Intermittently

Standard Setting on Relief Valves – 750 PSI Differential between Outlet and Inlet Pressure

*Note that these relief valves do not offer system relief protection. They simply limit the pressure between the outlet and inlet of the flow divider, and will aid in re-phasing whenever as section runs against a stop.*

Standard Ports – 1 5/16 12 SAE Inlet, 1 1/16-12 SAE Outlet

**WARNING:** The specifications/application data shown in our catalogs and data sheets are intended only as a general guide for the product described (herein). Any specific application should not be undertaken without independent study, evaluation, and testing for suitability.

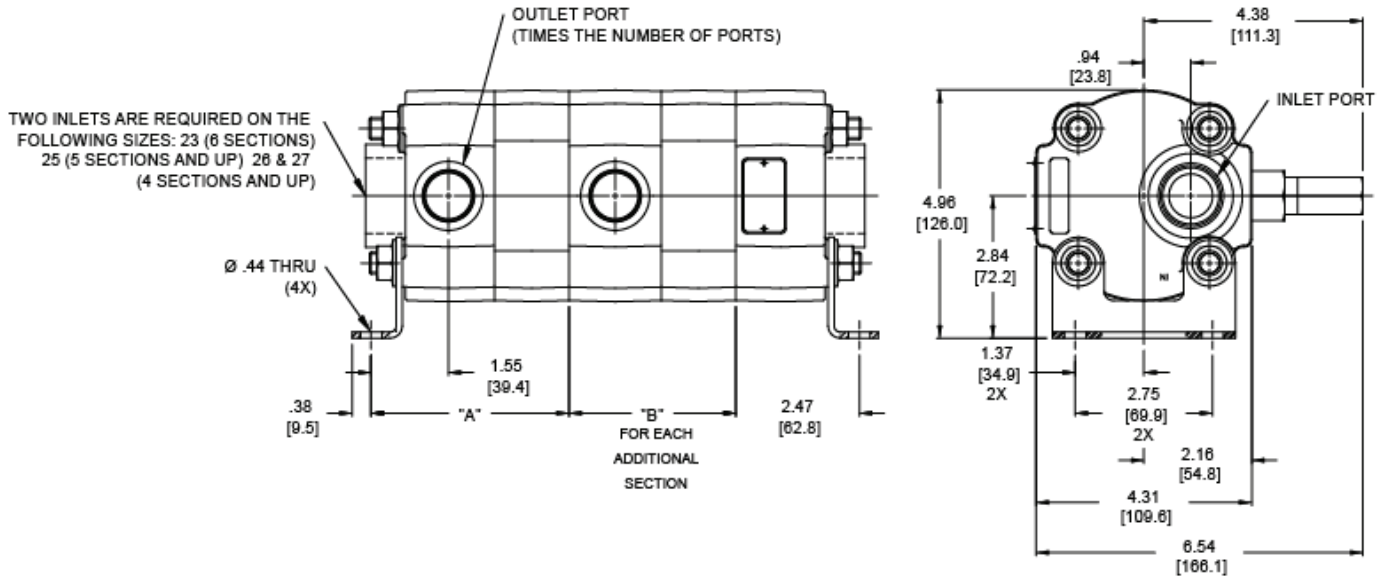

EQUAL FLOW				
TWO SECTION				
(2) SECTION MODEL	0 PSI DISPLACEMENT PER SECTION GAL./REV,	DIMENSION		MAX. INLET @3500 RPM GPM [LPM]
		A	B	
HPR23	0.00304	3.19 [81.0]	2.56 [65.0]	21 GPM [79 LPM]
HPR27	0.06330	3.96 [100.6]	3.34 [84.8]	44 GPM [166 LPM]

Note: Dimensions in [XX.X] are mm

EQUAL FLOW				
MULTI-SECTION				
(MIXED FLOW BUILDABLE ARE ALSO AVAILABLE)				
(4) SECTION MODEL	0 PSI DISPLACEMENT PER SECTION GAL./REV,	DIMENSION		MAX. INLET @3500 RPM GPM [LPM]
		A	B	
HPR21-59	0.00178	2.89 [73.4]	2.26 [57.4]	25 GPM [95 LPM]
HPR23-59	0.00304	3.19 [81.0]	2.56 [65.0]	42 GPM [160 LPM]
HPR25-59	0.00425	3.47 [88.1]	2.85 [72.4]	59 GPM [223 LPM]
HPR26-59	0.00531	3.72 [94.5]	3.10 [78.7]	74 GPM [280 LPM]
HPR27-59	0.00633	3.96 [100.6]	3.34 [84.8]	88 GPM [333 LPM]

Note: Dimensions in [XX.X] are mm

**FOR QUIETER OPERATION LIMIT SPEED TO 2000 RPM**

**WARNING:** The specifications/application data shown in our catalogs and data sheets are intended only as a general guide for the product described (herein). Any specific application should not be undertaken without independent study, evaluation, and testing for suitability.