

# AIR OVER OIL RESERVOIRS

## WALL MOUNT

Air over oil reservoirs provide precision hydraulic power from shop air. Exact cylinder movement is achieved without the high cost of conventional hydraulic power requiring pump, motor, filter, etc.

Basic circuits, when used with low pressure hydraulic check, flow control and directional valves, allow oil (driven at 1:1 ratio) to force piston rod at the same speed through both forward and return stroke. The speed control is adjustable to your work requirement.

### Standard Materials:

- Aluminum base and cover
- Buna N seals
- Break resistant, colorless, transparent polymer
- Aluminum bowl and sight gage may be specified

### Temperature and Pressure Ratings:

- Maximum working temperature
  - Polymer up to 140°F (60°C)
  - Aluminum up to 250°F (121.1°C)
- Maximum working pressure
  - Polymer up to 60 PSI (413.7 kPa)
  - Aluminum up to 100 PSI (689.5 kPa)

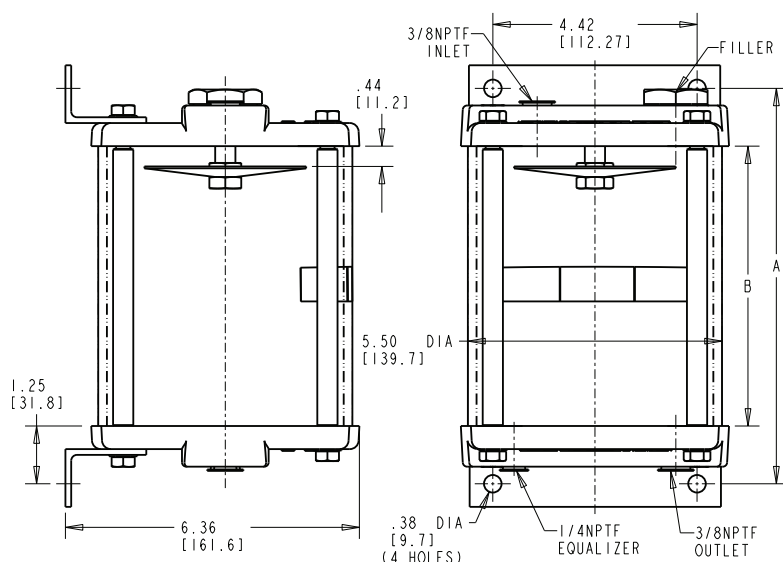

**NOTE:** All dimensions are inches [mm]

Air Over Oil Reservoir - Wall Mount					
Part No.		Capacity inches <sup>3</sup> (cm <sup>3</sup> )		A	B
Polymer	Aluminium w/gage	Polymer	Alum.	inches (mm)	inches (mm)
A/OR5075-3	—	97.00 (1589.50)	102.0 (1671.50)	7.06 (179.32)	4.56 (115.82)
A/OR5100-3	—	127.00 (2081.20)	133.00 (2179.50)	8.56 (217.42)	6.06 (153.92)
—	A/OR15175-3	196.00 (3211.90)	205.00 (3359.30)	12.06 (306.32)	9.56 (242.82)
A/OR5200-3	—	220.0 (3605.2)	231.0 (3785.4)	13.31 (388.07)	10.81 (274.57)

**MADE TO ORDER MODIFICATIONS AVAILABLE - CONSULT OUR FACTORY (MINIMUM ORDER MAY BE REQUIRED)**

Dimensions and specifications are subject to change without notice. Not all items are Made-To-Stock, contact us for availability.

02/14

Ph : 920-682-6877  
Fx : 920-684-7210



sales@ldi-industries.com  
www.ldi-industries.com