

SIGHT PLUGS

LSP51 SERIES

The LSP51 Series fused high pressure steel sight plug has a clear glass sight and male NPT thread connection. The fused, one-piece construction allows for higher operating temperatures and pressures. The sight plug can be accessorized with reflector and float ball. Boxed quantities may apply.

Standard Features:

- Stud end sizes from 1/4 NPT to 2-11½ NPT
- Fused clear glass sight
- Electroless Nickel finish
- Available with open view, with reflector or with reflector and float ball

Standard Materials:

- Carbon steel construction
- Stainless Steel reflector (when applicable)

Temperature and Pressure Ratings:

- Maximum operating temperature, 500°F (260°C)
- See chart below for pressure ratings

CAUTION:

- Do not use an impact wrench to install a sight plug
- Not recommended for steam applications
- Scratched glass significantly reduces the pressure rating of the sight plug

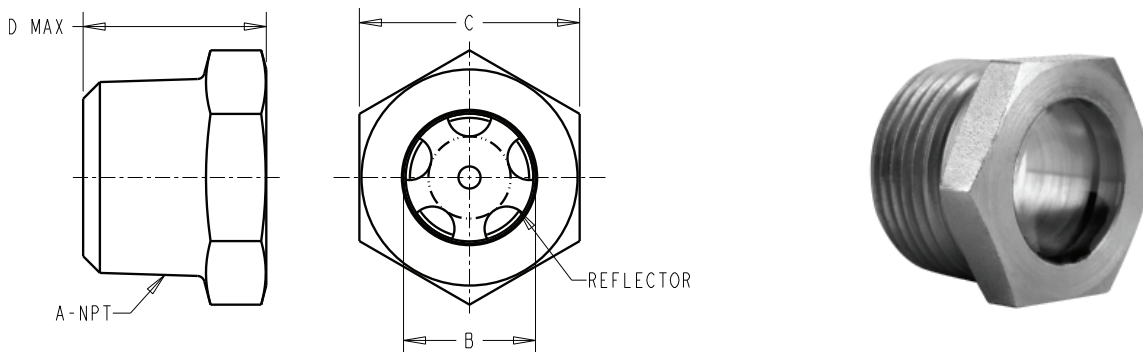

NOTE: All dimensions are inches (mm)

LSP51 Series							
Part No.		Min/Mult Box Quantity	A NPT	B inches (mm)	C inches (mm)	D inches (mm)	Max. Work. Pressure @ 69° F (20 °C) PSI (kPa)
Open View	Reflector						
LSP51-02	-	25	1/4-18	.34 (8.64)	.62 (15.75)	.64 (16.26)	2000 (13790)
LSP51-03	LSP51-03-01	25	3/8-18	.44 (11.18)	.75 (19.05)	.73 (18.54)	1850 (12755)
LSP51-04	LSP51-04-01	25	1/2-14	.56 (14.22)	.94 (23.88)	.79 (20.07)	1750 (12066)
LSP51-05	LSP51-05-01	25	3/4-14	.75 (19.05)	1.06 (26.92)	.95 (24.13)	1500 (10342)
LSP51-06	LSP51-06-01	15	1-11 1/2	.94 (23.88)	1.38 (35.05)	1.07 (27.18)	1250 (8618)
LSP51-07	LSP51-07-01	15	1 1/4-11 1/2	1.19 (30.23)	1.75 (44.45)	1.23 (31.24)	1000 (6895)
LSP51-08	LSP51-08-01	10	1 1/2-11 1/2	1.44 (36.58)	2.00 (50.80)	1.23 (31.24)	750 (5171)
LSP51-09	LSP51-09-01	10	2-11 1/2	1.88 (47.75)	2.50 (63.50)	1.28 (32.77)	500 (3447)

Dimensions and specifications are subject to change without notice. Not all items are Made-To-Stock, contact us for availability.

02/14

Ph : 920-682-6877
Fx : 920-684-7210



sales@ldi-industries.com
www.ldi-industries.com