

SIGHT GAGES - CLOSED CIRCUIT

G645 SERIES

The G645 front mount closed circuit sight gages provide front viewing of the fluid level clearly delineated by a redline on white background integral to the glass sight all secured within an aluminum body (HIGH-LOW markings). A dry dial thermometer allows for temperature monitoring. The thermowell for the thermometer also serves as one of the mounting bolts for the sight gage. This construction allows the thermometer orientation to be adjusted independent of the sight gage and removed if necessary without having to drain the reservoir.

Standard Features:

- Front mount
- Fluid level visible from front of gage (.50 inches wide)
- Viewing enhanced by redline on white background integral to sight glass
- 2.00" diameter dual scale dial thermometer, 0° to 300°F and -20° to 150°C
- Dial thermometer may be removed from a filled reservoir without loss of fluid
- Suitable for use with most hydraulic and machine lubricating oils

Standard Materials:

- Aluminum construction
- Buna N seals
- Borosilicate glass sight
- Zinc plated, steel hex nuts

Temperature and Pressure Ratings:

- Please refer to Appendix RA-1 on page RA-A1 for Sight Opening & Pressure Rating information
- Please refer to Temperature Ratings by Seal Material for additional operating conditions (Appendix RA-5 on page RA-A5)

NOTE:

- Please refer to Appendix RA-2 on page RA-A2 for installation instructions

CAUTION: • Not recommended for use with water, steam, acidic fluids, caustic fluids and volatile fluids

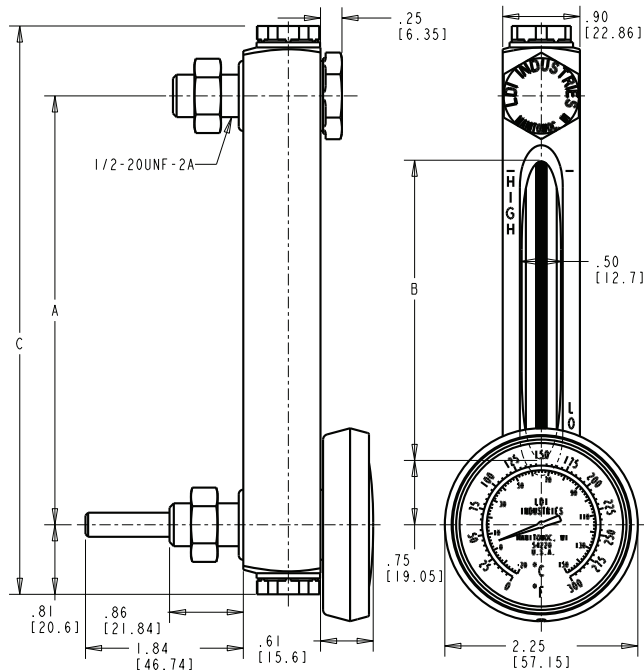

G645 Series		
A inches (mm)	B inches (mm)	C inches (mm)
5.00 (127.00)	3.50 (88.90)	6.62 (168.15)
8.00 (203.20)	6.50 (165.10)	9.62 (244.35)
10.00 (254.00)	8.50 (215.90)	11.62 (295.15)
12.00 (304.80)	10.50 (266.70)	13.62 (345.95)



NOTE: All dimensions are inches [mm]

ORDERING OPTIONS CODES:

Select mounting centers of 5.00 inches (127.00 mm), 8.00 inches (203.20 mm) or 10.00 inches (254.00 mm) available from stock.

Consult factory for other lengths

BODY MATERIAL

- A- Aluminum gage body (standard)
- B- Brass gage body (optional)
- S- Steel gage body (optional)
- Y- Stainless Steel gage body (optional)

SEAL MATERIAL

- 1- Buna N seals (standard)
- 2- Butyl seals (optional)
- 3- Viton® seals (optional)
- 4- Ethylene propylene seals (optional)
- 5- Silicone seals (optional)

HOW TO ORDER

EXAMPLE:

G645-05-A-1 — Buna N Seals
 Aluminum gage body
 5.00 (127.00 mm) mounting centers
 Series G645

Dimensions and specifications are subject to change without notice. Not all items are Made-To-Stock, contact us for availability.

06/18

Ph : 920-682-6877
 Fx : 920-684-7210



sales@ldi-industries.com
 www.ldi-industries.com