

# SIGHT GAGES - CLOSED CIRCUIT

## G635 SERIES

The G635 Series front mount closed circuit sight gage provides 270° of viewing the fluid level clearly delineated by a redline on white background integral to the sight glass all secured within an aluminum body (HIGH-LOW markings). The oversized gage body allows a deeper recess of the sight glass for maximum protection of the sight glass against damage.

### Standard Features:

- Front mount
- 270° of viewing the fluid level (.88 inch front and .50 inch side width windows)
- Viewing enhanced by redline on white background integral to sight glass
- Suitable for use with most hydraulic and machine lubricating oils

### Standard Materials:

- Aluminum gage body and mounting bolts
- Buna N seals
- Borosilicate glass sight
- Zinc plated, steel hex nuts

### Temperature and Pressure Ratings:

- Please refer to Appendix RA-1 on page RA-A1 for Sight Opening & Pressure Rating information
- Please refer to Temperature Ratings by Seal Material for additional operating conditions (Appendix RA-5 on page RA-A5))

### NOTE:

- Please refer to Appendix RA-2 on page RA-A2 for installation instructions

**CAUTION:** - Not recommended for use with water, steam, acidic fluids, caustic fluids and volatile fluids  
 - If aluminum construction is selected for a water application, anodizing is recommended

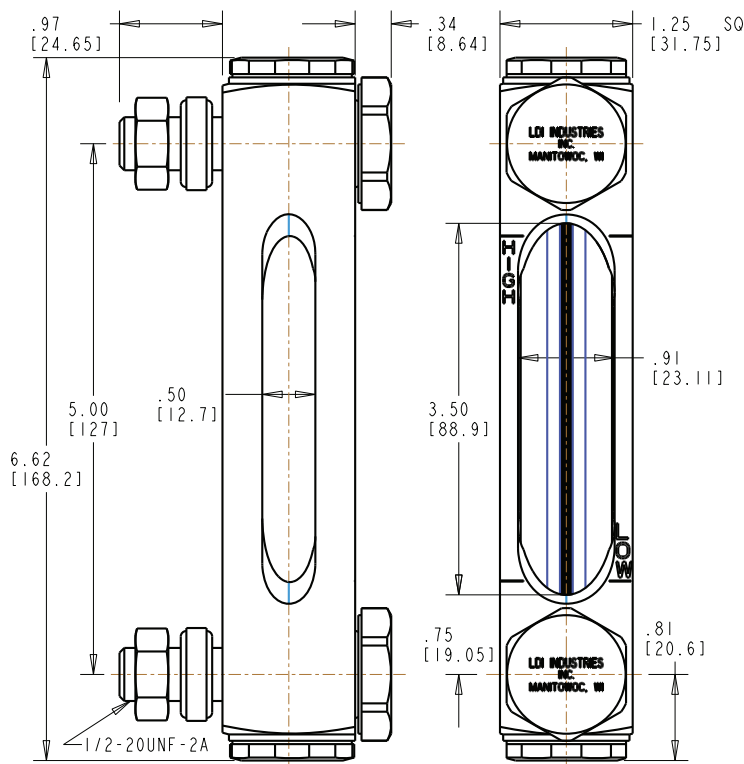

**NOTE:** All dimensions are inches [mm]

### ORDERING OPTIONS CODES:

#### BODY MATERIAL

- A- Aluminum gage body (standard)
- B- Brass gage body (optional)

#### SEAL MATERIAL

- 1- Buna N seals (standard)
- 2- Butyl seals (optional)
- 3- Viton® seals (optional)
- 4- Ethylene propylene seals (optional)
- 5- Silicone seals (optional)

### HOW TO ORDER

#### EXAMPLE:

- G635-05-A-1** — Buna N Seals  
 Aluminum gage body  
 5.00 (127.00 mm) mounting centers  
 Series G635

Dimensions and specifications are subject to change without notice. Not all items are Made-To-Stock, contact us for availability.

02/14

Ph : 920-682-6877  
 Fx : 920-684-7210



sales@ldi-industries.com  
 www.ldi-industries.com