

SIGHT GAGES - CLOSED CIRCUIT

G620 SERIES

The G620 Series back mount closed circuit sight gages provide front viewing of the fluid level clearly delineated by a redline on white background integral to the sight glass all secured within an aluminum body (HIGH-LOW markings). A wetted dial thermometer provides an analog display of the fluid temperature.

Standard Features:

- Back mount
- Fluid level visible from front of gage (.50 inches wide)
- Viewing enhanced by redline on white background integral to sight glass
- 1.38" diameter dual scale dial thermometer, 50° to 300°F and 10° to 150°C
- Aluminum tube shields thermometer probe extending into reservoir
- Suitable for use with most hydraulic and machine lubricating oils

Standard Materials:

- Aluminum gage body
- Buna N seals
- Borosilicate glass sight
- Zinc plated, steel hex nuts

Temperature and Pressure Ratings:

- Please refer to Appendix RA-1 on page RA-A1 for Sight Opening & Pressure Rating information
- Please refer to Temperature Ratings by Seal Material for additional operating conditions (Appendix RA-5 on page RA-A5)

NOTES:

- Access to inside of reservoir is required to mount this style sight gage
- Please refer to Appendix RA-3 on page RA-A3 for installation instructions

CAUTION: • Not recommended for use with water, steam, acidic fluids, caustic fluids and volatile fluids
 • If aluminum construction is selected for a water application, anodizing is recommended
 • Reservoir must be drained to remove dial thermometer or loss of fluid will occur

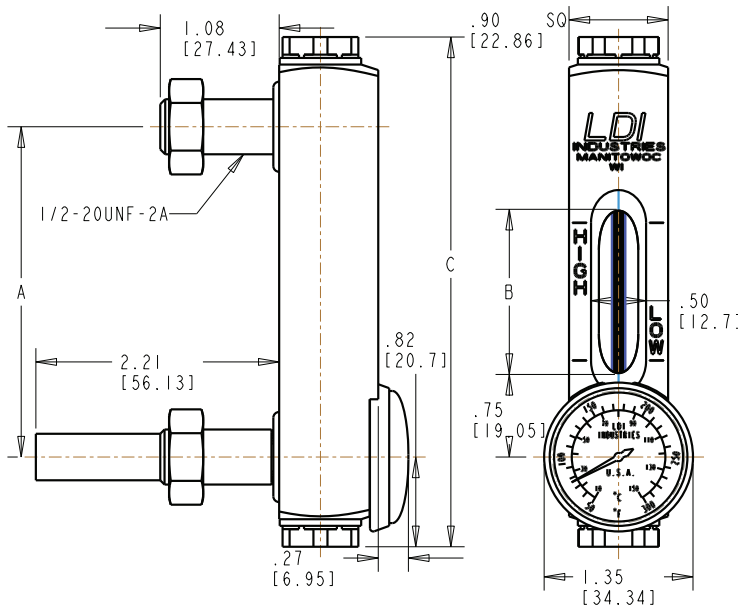

G620 Series		
A	B	C
inches (mm)	inches (mm)	inches (mm)
3.00 (76.20)	1.50 (38.10)	4.62 (117.35)
4.00 (101.60)	2.50 (63.50)	5.62 (142.75)
5.00 (127.00)	3.50 (88.90)	6.62 (168.15)
6.00 (152.40)	4.50 (114.30)	7.62 (193.55)
7.00 (177.80)	5.50 (139.70)	8.62 (218.95)
8.00 (203.20)	6.50 (165.10)	9.62 (244.35)
9.00 (228.60)	7.50 (190.50)	10.62 (269.75)
10.00 (254.00)	8.50 (215.90)	11.62 (295.15)
12.00 (304.80)	10.50 (266.70)	13.62 (345.95)



NOTE: All dimensions are inches [mm]

ORDERING OPTIONS CODES:

BODY MATERIAL

- A- Aluminum gage body (standard)
- B- Brass gage body (optional)
- S- Steel gage body (optional)
- Y- Stainless Steel gage body (optional)

SEAL MATERIAL

- 1- Buna N seals (standard)
- 2- Butyl seals (optional)
- 3- Viton® seals (optional)
- 4- Ethylene propylene seals (optional)
- 10- Neoprene seals (optional)

NOTE: The sight opening in all cases is 1.50 inch (38.10mm) less than mounting centers and overall length is 1.62 inch (41.15mm) greater than mounting centers.

HOW TO ORDER

EXAMPLE:

G620-05-A-1 — Buna N Seals
 — Aluminum gage body
 — 5.00 (127.00 mm) mounting centers
 — Series G620

Dimensions and specifications are subject to change without notice. Not all items are Made-To-Stock, contact us for availability.

02/14

Ph : 920-682-6877
 Fx : 920-684-7210



sales@ldi-industries.com
 www.ldi-industries.com