

SIGHT GAGES - CLOSED CIRCUIT

G615 SERIES

The G615 Series front mount closed circuit sight gages provide front viewing of the fluid level clearly delineated by a redline on white background integral to the glass sight all secured within an aluminum body. HIGH-LOW markings are stamped into the aluminum body and a wetted dial thermometer provides direct reading of the fluid temperature.

Standard Features:

- Front mount
- Fluid level visible from front of gage (.50 inches wide)
- Viewing enhanced by redline on white background integral to sight glass
- 1.38" diameter dual scale dial thermometer, 50° to 300°F and 10° to 150°C
- Suitable for use with most hydraulic and machine lubricating oils

Standard Materials:

- Aluminum gage body and mounting bolts
- Buna N seals
- Borosilicate glass sight
- Zinc plated, steel hex nuts

Temperature and Pressure Ratings:

- Please refer to Appendix RA-1 on page RA-A1 for Sight Opening & Pressure Rating information
- Please refer to Temperature Ratings by Seal Material for additional operating conditions (Appendix RA-5 on page RA-A5)

NOTE:

- Please refer to Appendix RA-2 on page RA-A2 for installation instructions

CAUTION: • Not recommended for use with water, steam, acidic fluids, caustic fluids and volatile fluids
 • If aluminum construction is selected for a water application, anodizing is recommended
 • Reservoir must be drained to remove dial thermometer or loss of fluid will occur

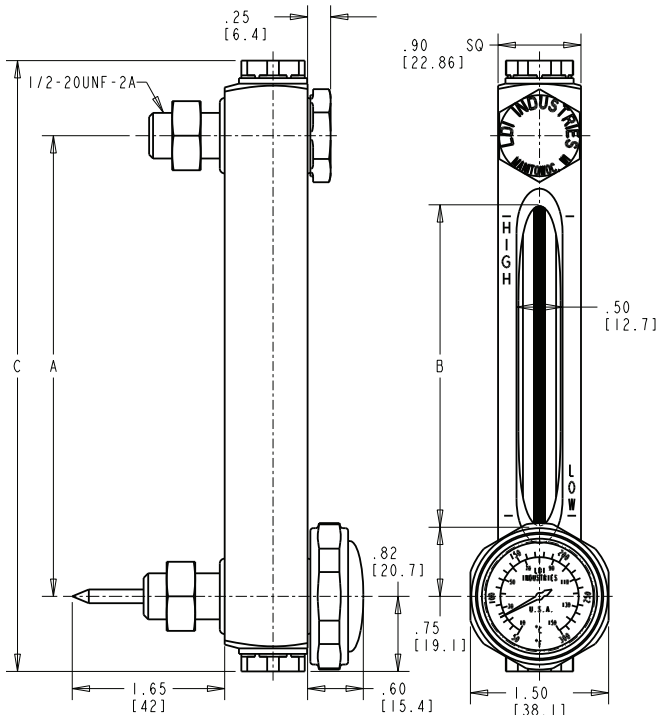

G615 Series		
A inches (mm)	B inches (mm)	C inches (mm)
3.00 (76.20)	1.50 (38.10)	4.62 (117.35)
4.00 (101.60)	2.50 (63.50)	5.62 (142.75)
5.00 (127.00)	3.50 (88.90)	6.62 (168.15)
6.00 (152.40)	4.50 (114.30)	7.62 (193.55)
7.00 (177.80)	5.50 (139.70)	8.62 (218.95)
8.00 (203.20)	6.50 (165.10)	9.62 (244.35)
9.00 (228.60)	7.50 (190.50)	10.62 (269.75)
10.00 (254.00)	8.50 (215.90)	11.62 (295.15)
11.00 (279.40)	9.50 (241.30)	12.62 (320.55)
12.00 (304.80)	10.50 (266.70)	13.62 (345.95)



NOTE: All dimensions are inches [mm]

NOTE: The sight opening in all cases is 1.50 inches (38.10mm) less than mounting centers and overall length is 1.62 inches (41.15mm) greater than mounting centers. Gages with 13.00 inch (330.20mm) and greater mounting centers are furnished with spacer sleeves to space gage from tank allowing for bowing of the tank wall in larger reservoirs. Center mounting kits are furnished with gages 48.00 inches (1219.20mm) and greater mounting centers.

ORDERING OPTIONS CODES:

BODY MATERIAL

- A- Aluminum gage body (standard)
- B- Brass gage body (optional)
- S- Steel gage body (optional)
- Y- Stainless Steel gage body (optional)

SEAL MATERIAL

- 1- Buna N seals (standard)
- 2- Butyl seals (optional)
- 3- Viton® seals (optional)
- 4- Ethylene propylene seals (optional)
- 10- Neoprene seals (optional)

HOW TO ORDER

EXAMPLE:

G615-05-A-1 — Buna N Seals
 Aluminum gage body
 5.00 (127.00 mm) mounting centers
 Series G615

Dimensions and specifications are subject to change without notice. Not all items are Made-To-Stock, contact us for availability.

02/14

Ph : 920-682-6877
 Fx : 920-684-7210



sales@ldi-industries.com
 www.ldi-industries.com