

COUPLING & FLANGE CONNECTIONS

RETURN FLANGES FOR PIPE AND TUBING

Suction/Return Flanges and Grommets are designed to seal pipe or tube lines when passing through the top plate of a hydraulic reservoir or similar applications. Suction Flanges also allow access for removal of a suction element for inspection without draining the reservoir.

Standard Features:

- (1) Flange
- (1) Internal washer
- (2) 1/4-20 thread forming screws

Standard Material:

- Zinc plated Carbon Steel

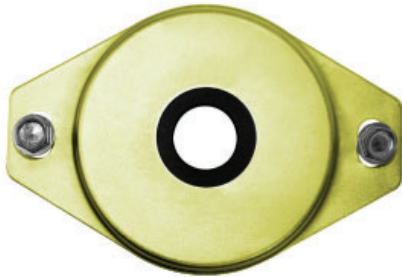
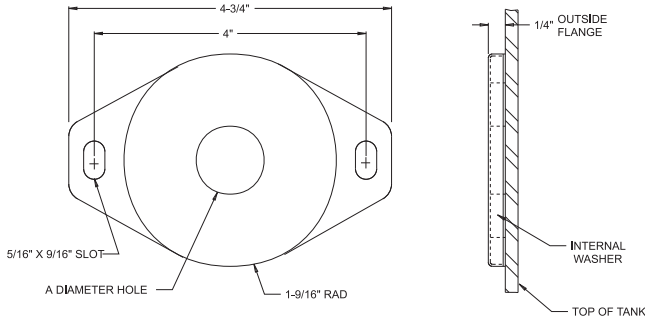

Return Flanges for Pipe		
Part No.	A Diameter Hole (inches)	Pipe Size (inches)
5110	1.19	1/2
5111	1.75	3/4
5112	1.75	1
5113	2.50	1 1/4
5114	2.50	1 1/2
5115	2.50	2

Return Flanges for Tube		
Part No.	A Diameter Hole (inches)	Tube Size OD (inches)
5772	1.19	3/8
5765	1.19	1/2
5766	1.19	5/8
5767	1.19	3/4
5768	1.75	1
5769	2.50	1 1/4
5770	2.50	1 1/2
5771	2.50	2

RUBBER GROMMETS FOR RESERVOIR DOWNPIPES

Standard Features:

- Blank size with 'E' hole shall be furnished.
- Maximum O.D. limited to 'B' dimension

Standard Material:

- Buna N rubber

NOTE:

- Drill hole in tank top per cutout size "F"
- Snap in grommet

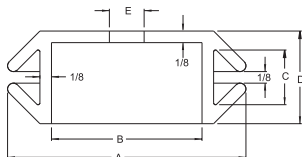
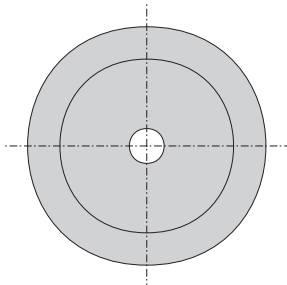

Rubber Grommets for Reservoir Downpipes						
Part No.	Dimensions (inches)					F Cutout Size
	A	B	C	D	E	
131499	1.88	.78	.62	1.00	.25	1.12
131599	2.38	1.20	.62	1.00	.25	1.44
131699	3.00	1.84	.62	1.00	.38	2.06
131799	3.50	2.41	.62	1.00	.50	2.62
131899	4.50	3.50	.69	1.19	.50	3.88

Dimensions and specifications are subject to change without notice. Not all items are Made-To-Stock, contact us for availability.

02/14

Ph : 920-682-6877
Fx : 920-684-7210



sales@ldi-industries.com
www.ldi-industries.com