

COUPLING & FLANGE CONNECTIONS

SUCTION FLANGES FOR PIPE/TUBING

Suction/Return Flanges and Grommets are designed to seal pipe or tube lines when passing through the top plate of a hydraulic reservoir or similar applications. Suction Flanges also allow access for removal of a suction element for inspection without draining the reservoir.

Standard Features:

- (1) Top plate
- (1) Internal washer
- (1) Bottom plate
- (1) Gasket
- (4) 5/16-18 thread forming screws

Standard Material:

- Zinc plated Carbon Steel

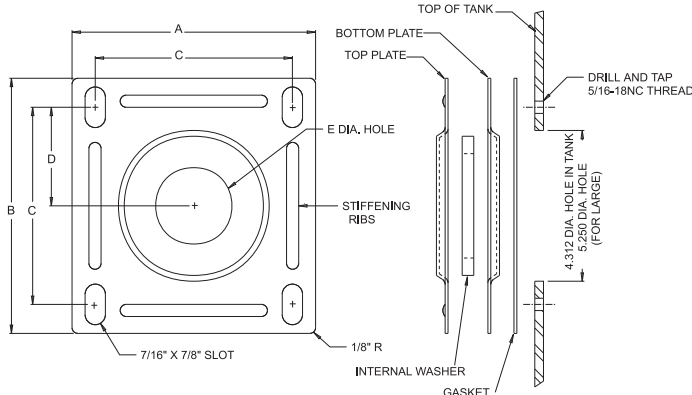

Part Numbers 5100-5179 and 5880-5891

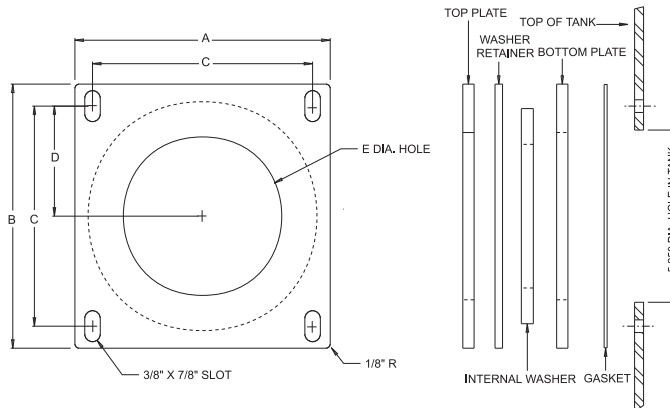
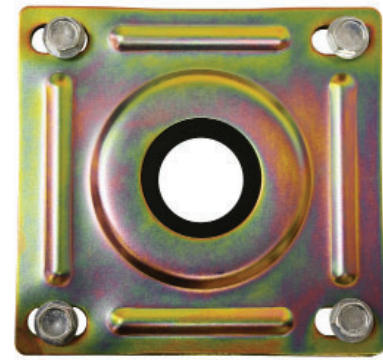

Part Numbers 5180-5181

Suction Flanges for Pipe						
Part No.	Dimensions (inches)					Pipe Size
	A	B	C	D	E	
5100	5.25	5.50	4.25	2.12	1.19	1/2
5101	5.25	5.50	4.25	2.12	1.19	3/4
5102	5.25	5.50	4.25	2.12	1.75	1
5103	5.25	5.50	4.25	2.12	1.75	1 1/4
5104	5.25	5.50	4.25	2.12	2.50	1 1/2
5105	5.25	5.50	4.25	2.12	2.50	2
5187	7.25	7.50	6.25	3.12	3.12	1 1/2
5188	7.25	7.50	6.25	3.12	3.12	2
5178	7.25	7.50	6.25	3.12	3.75	2 1/2
5179	7.25	7.50	6.25	3.12	3.75	3
5180	7.25	7.50	6.25	3.12	4.75	3 1/2
5181	7.25	7.50	6.25	3.12	4.75	4

Suction Flanges for Tubing						
Part No.	Dimensions (inches)					Tube Size OD
	A	B	C	D	E	
5891	5.25	5.50	4.25	2.12	1.19	.38
5880	5.25	5.50	4.25	2.12	1.19	.50
5881	5.25	5.50	4.25	2.12	1.19	.62
5882	5.25	5.50	4.25	2.12	1.19	.75
5883	5.25	5.50	4.25	2.12	1.75	1.00
5884	5.25	5.50	4.25	2.12	1.75	1.25
5885	5.25	5.50	4.25	2.12	2.50	1.50

Dimensions and specifications are subject to change without notice. Not all items are Made-To-Stock, contact us for availability.

02/14

Ph : 920-682-6877
Fx : 920-684-7210



sales@ldi-industries.com
www.ldi-industries.com