

# ACCESS COVERS

## 6 INCH ACCESS COVER

Access Covers (Cleanout Covers) are designed to allow access into a dry (drained) reservoir for cleaning, inspection or mounting of components inside of the reservoir.

### Standard Features:

1. (1) 3/8 inch x 1-1/4 inch long hex head bolt
2. (1) Nylon washer
3. Cover
4. Buna N flat gasket
5. Back cover with weld nut

### Standard Material:

- Zinc plated carbon steel

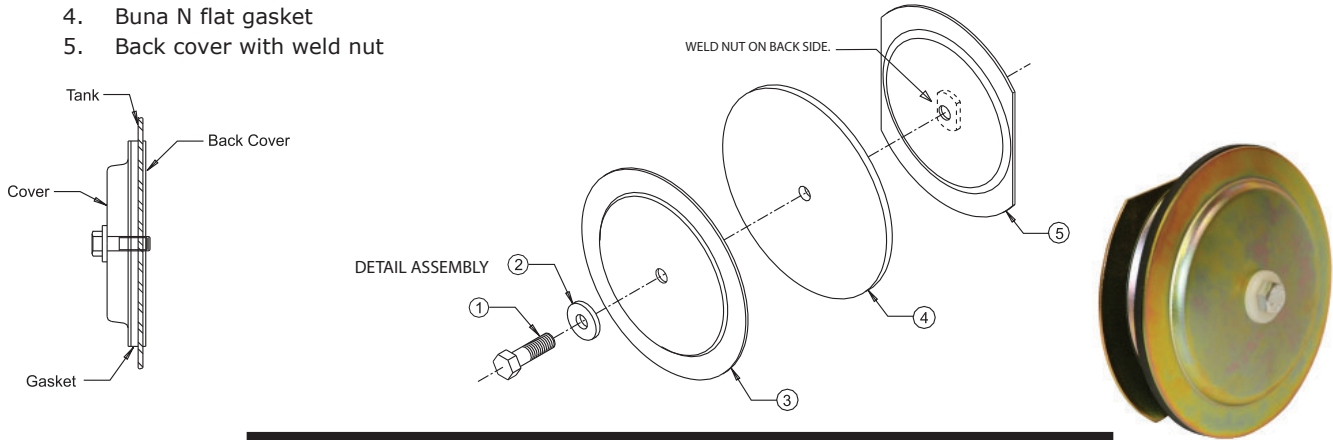

6 Inch Access Cover		
Part No.	Opening Diameter (inches)	Recommended Torque (ft-lb)
V1917	4 5/8	8

## BAFFLE MOUNT – STEEL W/ FLOW RESTRICTORS

Access Covers (Cleanout Covers) with flow restrictors are designed to help prevent hydraulic fluid from by-passing the baffle cutout by flowing around the cover dome. It will also allow access into a dry (drained) reservoir for cleaning, inspection or mounting of components inside of the reservoir.

### Standard Features:

- Center clearance hole for mounting bolt
- One piece design
- With or without drain connection
- Buna N lip gasket

### Standard Material:

- Carbon Steel

### NOTES:

- Stainless steel also available upon request
- Recommended Torque = 15 ft-lb

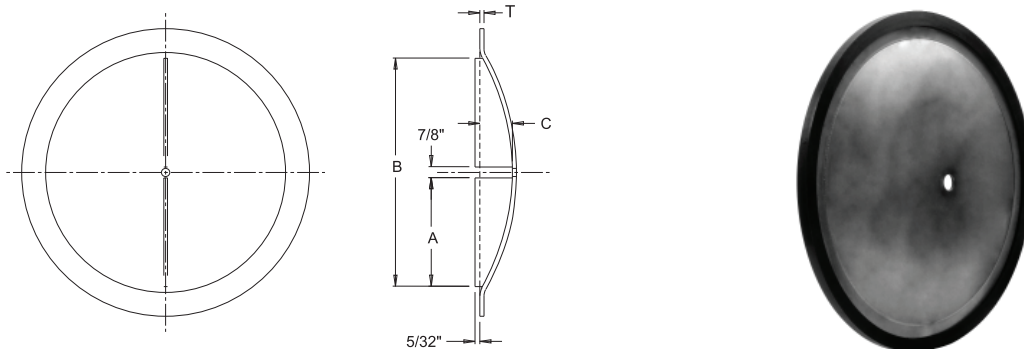

**NOTE:** All dimensions are inches

Access Covers: Baffle Mount - Steel w/Flow Restrictors								
Access Cover Size (inches)	Dimensions				Access Cover Openings (inches)	Steel Access Cover w/Restrictor w/Drain Part No.	Steel Access Cover w/Restrictor w/o Drain Part No.	Steel Access Cover w/Restrictor w/SAE-12 Drain Part No.
	A (inches)	B (inches)	C (inches)	T				
12	4.50	9.88	1.50	7 GA	10.00	5080-R	50800-R	50540
14	5.00	11.88	1.50	7 GA	12.00	5065-R	5066-R	50550
16	5.62	12.12	1.75	7 GA	12.25	5087-R	50870-R	50560
18	7.50	15.88	2.25	7 GA	16.00	5091-R	50910-R	50570

Dimensions and specifications are subject to change without notice. Not all items are Made-To-Stock, contact us for availability.

09/18

Ph : 920-682-6877  
Fx : 920-684-7210



sales@ldi-industries.com  
www.ldi-industries.com