

DIFFERENTIAL POPPET STYLE RELIEF VALVES - RV AND DRV SERIES

MODEL RV DIFFERENTIAL POPPET INLINE RELIEF

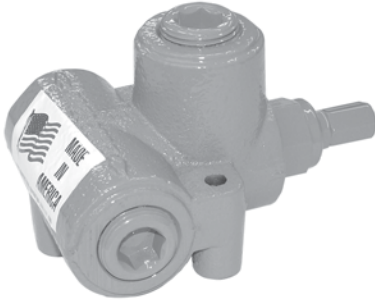

The PRINCE valve model RV is a differential poppet type inline relief. The valve is made up of a relief cartridge and a cast iron valve body. The differential poppet type relief provides smooth quiet performance with a minimum variation between cracking and full flow pressures. This type relief is also less sensitive to system contamination. The model RV is well suited as a system relief up to 30 GPM and 3000 psi. It is available in two pressure ranges and both an externally adjustable and shim adjustable version.

VALVE SPECIFICATIONS:

Capacity: 30 gpm max inlet flow Weight: 3 lbs.
Pressure: 3000 psi max

MODEL DRV DIFFERENTIAL POPPET DOUBLE RELIEF



The PRINCE valve model DRV is a differential poppet type double relief. This valve uses the same relief cartridge as the model RV. The double relief is used in systems that require cross over relief protection such as reversible hydraulic motor, or systems that require a cushion valve such as double acting cylinders.

VALVE SPECIFICATIONS:

Capacity: 30 gpm max inlet flow Weight: 5.5 lbs.
Pressure: 3000 psi max

MODEL RV-O DIFFERENTIAL POPPET RELIEF CARTRIDGE

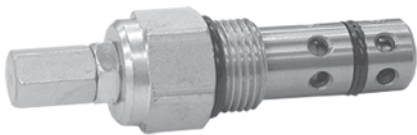

The PRINCE valve model RV-O is the differential poppet relief cartridge used in many valve models. It is available preset to install into RV valves in the field or into a custom application. This relief cartridge can also be used in the RD5100, RD5200, RD5300 and SV stack valve inlet section.

VALVE SPECIFICATIONS:

Capacity: 30 gpm max inlet flow
Pressure: 3000 psi max

STANDARD MODELS AVAILABLE

MODEL NUMBER	MODEL NUMBER	VALVE TYPE	RELIEF SETTING	PORT SIZE
RV-1H	DRV-1HH	ADJUSTABLE 1500-3000 PSI	2000 PSI @ 10 GPM	#12 SAE
RV-2H	DRV-2HH	ADJUSTABLE 1500-3000 PSI	2000 PSI @ 10 GPM	3/4" NPTF
RV-4H	DRV-4HH	ADJUSTABLE 1500-3000 PSI	2000 PSI @ 10 GPM	1/2" NPTF
RV-2L	DRV-2LL	ADJUSTABLE 500-1500 PSI	1000 PSI @ 10 GPM	3/4" NPTF

MODEL RV AND DRV SPECIAL MODELS AND MOUNTING DIMENSIONS

SPECIAL MODEL RV RELIEF VALVES

Other relief valve models not listed on previous page are available in OEM quantities. To select a model number use the order code matrix shown at right. Consult a sales representative if options other than those listed are required.

MODEL NUMBER	PORT SIZE	RELIEF TYPE	PRESSURE SETTING
RV	1 - #12 SAE 2 - 3/4 NPTF 3 - #10 SAE 4 - 1/2 NPTF 5 - #8 SAE O - Cartridge Only. No Body.	H- Adjustable 1500-3000 PSI L- Adjustable 500-1500 PSI NH- Non-Adjustable 1500-3000 PSI NL- Non-Adjustable 500-1500 PSI	Specify Relief Pressure in PSI. Leave Blank for Standard Setting <u>STANDARD SETTING</u> 2000 PSI for H and NH 1000 PSI for L and NL

SPECIAL MODEL DRV RELIEF VALVES

Other relief valve models not listed on previous page are available in OEM quantities. To select a model number using the order code matrix at right. Consult a sales representative if options other than those listed are required.

MODEL NUMBER	PORT SIZE	RELIEF TYPE		RELIEF SETTINGS (PSI)
		Port A/B #1	Port C/D #2	Port A/B Port C/D
DRV	1 - #12 SAE 2 - 3/4 NPTF 3 - #10 SAE 4 - 1/2 NPTF 5 - #8 SAE	H- Adjustable 1500-3000 PSI L- Adjustable 500-1500 PSI NH- Non-Adjustable 1500-3000 PSI NL- Non-Adjustable 500-1500 PSI	H- Adjustable 1500-3000 PSI L- Adjustable 500-1500 PSI NH- Non-Adjustable 1500-3000 PSI NL- Non-Adjustable 500-1500 PSI	Relief Settings: The two digits represent the relief settings in 100s to the nearest 100 PSI for the respective ports. EXAMPLE: 08 = 800 PSI 17 = 1700 PSI

RV-SERIES MOUNTING DIMENSIONS

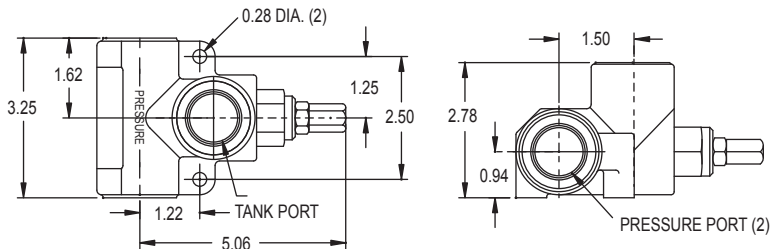

RV-SERIES RELIEF CURVES

AT VARIOUS SET POINTS.
110 SUS OIL AT 115°F.

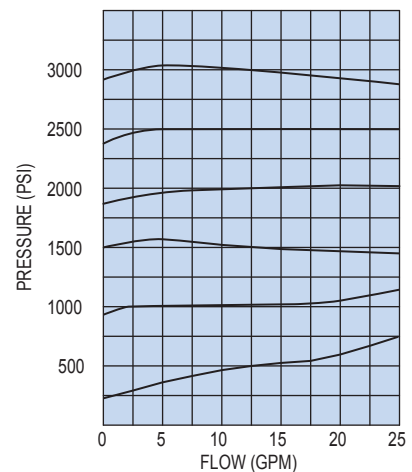

DRV-SERIES MOUNTING DIMENSIONS

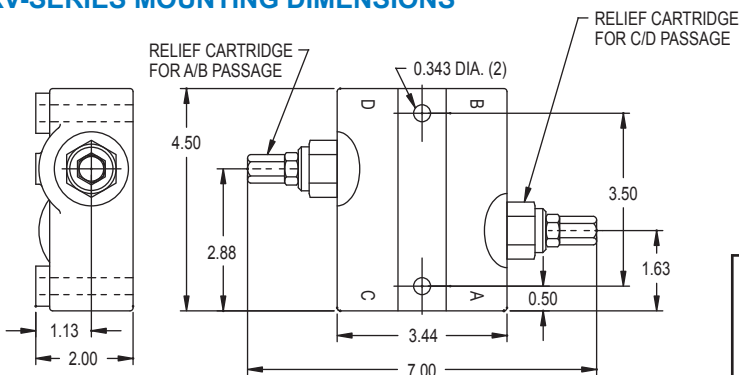

MACHINING DIMENSIONS FOR RELIEF VALVE CARTRIDGE

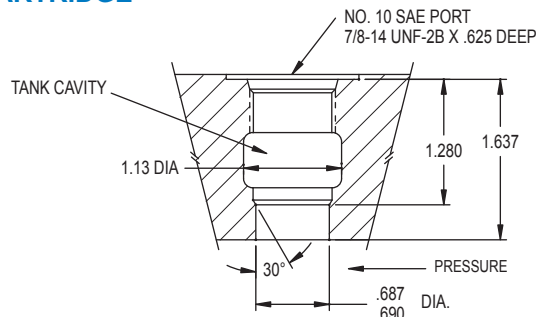

FIELD CONVERSION KITS:

- 660250002 ADJ. RELIEF CARTRIDGE 1500-3000 PSI RV ONLY
- 660250003 ADJ. RELIEF CARTRIDGE 500-1500 PSI*
- 660250004 NON-ADJUSTABLE RELIEF CARTRIDGE 1500-3000 PSI RV ONLY
- 660250005 NON-ADJUSTABLE RELIEF CARTRIDGE 500-1500 PSI*
- 660250011 ADJ. RELIEF CARTRIDGE 1500-3000 PSI DRV ONLY
- 660250012 NON-ADJUSTABLE RELIEF CARTRIDGE 1500-3000 DRV ONLY
- 660590001 RV SEAL KIT
- 660590004 DRV SEAL KIT
- 670300005 1500-3000 PSI RELIEF SPRING
- 670300006 500-1500 PSI RELIEF SPRING

* NOTE: THESE CARTRIDGES ARE THE SAME ON BOTH RV AND DRV VALVES

VALVES