

FOOT MOUNTING BRACKETS

SAE B 2/4-BOLT

This Foot Mounting Bracket is designed to mount a SAE B 2 or 4-bolt hydraulic pump or motor with supporting feet.

Standard Features:

- Light weight - High strength
- Four foot mounting holes provided
- Machined to a 5.375 inch shaft centerline height

Standard Material:

- Cast Aluminum

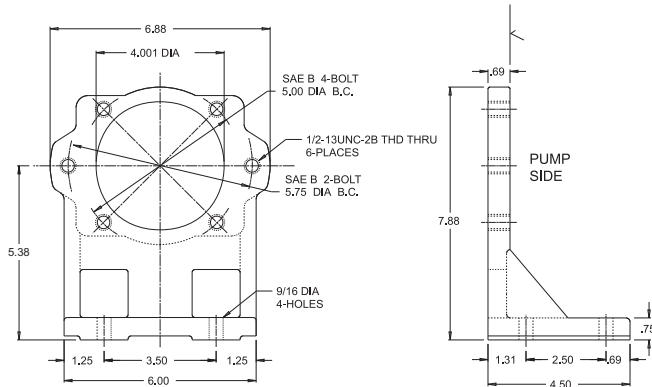

NOTE: All dimensions are inches

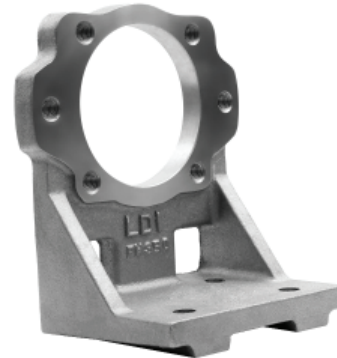

SAE B 2/4-Bolt Foot Mounting Bracket

Part No.	Description
FM350	SAE B 2/4-Bolt Foot Bracket

SAE C 2/4-BOLT

This Foot Mounting Bracket is designed to mount a SAE C 2 or 4-bolt hydraulic pump or motor with supporting feet.

Standard Features:

- Light weight - High strength
- Four foot mounting holes provided
- Machined to a 4.312 inch shaft centerline height

Standard Material:

- Cast Iron

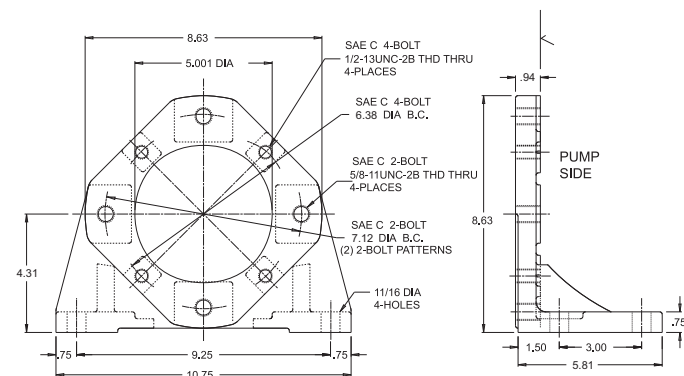

NOTE: All dimensions are inches



SAE C 2/4-Bolt Foot Mounting Bracket

Part No.	Description
FM400	SAE C 2/4-Bolt Foot Bracket

Dimensions and specifications are subject to change without notice. Not all items are Made-To-Stock, contact us for availability.

02/14

Ph : 920-682-6877
Fx : 920-684-7210



sales@ldi-industries.com
www.ldi-industries.com