

FLOW SIGHTS

F50/60 SERIES

Compact design inline flow sights may be used in either horizontal or vertical pipe runs to indicate flow. May also be used to check clarity of fluid. Machined from solid brass bar stock with large sight windows.

Standard Materials:

- Brass construction
- Buna N seals
- Borasilicate sight

Temperature and Pressure Ratings:

- Maximum working temperature up to 200°F (93°C)
- Maximum working pressure up to 50 PSI (345 kPa) at 70°F (21°C)
- No corrosion

Caution:

Scratched glass significantly reduces pressure rating.

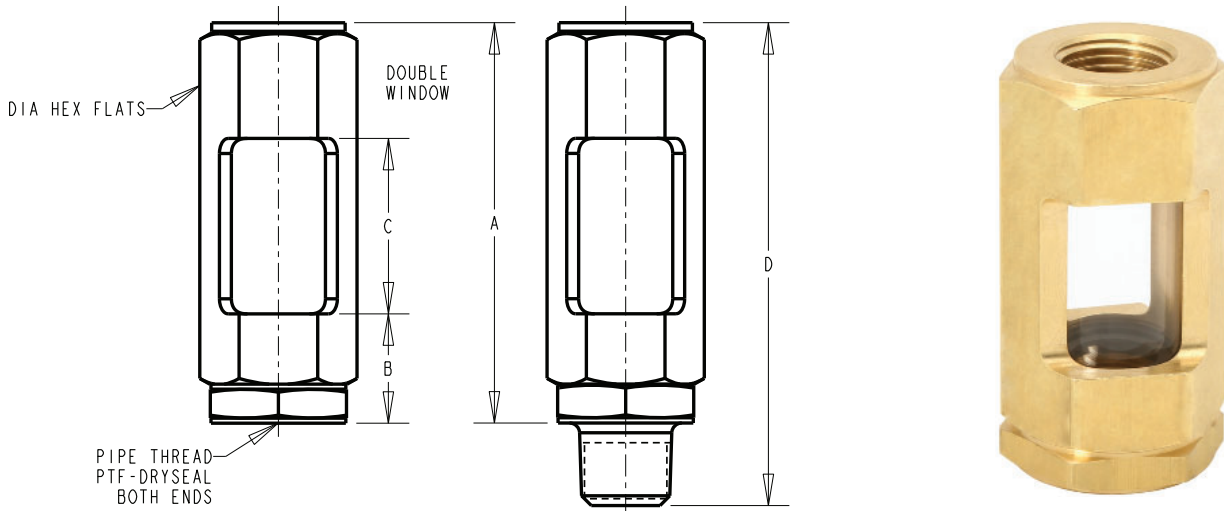

F50/60 Series							
Part No.		Pipe Thread	Hex Flats inches (mm)	A inches (mm)	B inches (mm)	C inches (mm)	D inches (mm)
Female X Female	Female X Male						
F52	F62	1/4-18	.81 (20.57)	2.41 (61.21)	.66 (16.76)	1.06 (26.92)	2.91 (73.91)
F53	—	3/8-18	1.12 (28.45)	2.38 (60.45)	.69 (17.53)	1.00 (25.40)	2.88 (73.15)
F56	—	1-11 1/2	2.50 (63.50)	3.50 (88.90)	.88 (22.35)	1.75 (44.45)	4.31 (109.47)
F57	—	1 1/4-11 1/2	2.50 (63.50)	3.50 (88.90)	.88 (22.35)	1.75 (44.45)	4.34 (110.24)

Dimensions and specifications are subject to change without notice. Not all items are Made-To-Stock, contact us for availability.

01/19

Ph : 920-682-6877
Fx : 920-684-7210



sales@ldi-industries.com
www.ldi-industries.com