

# J Series (129-)

## Specifications

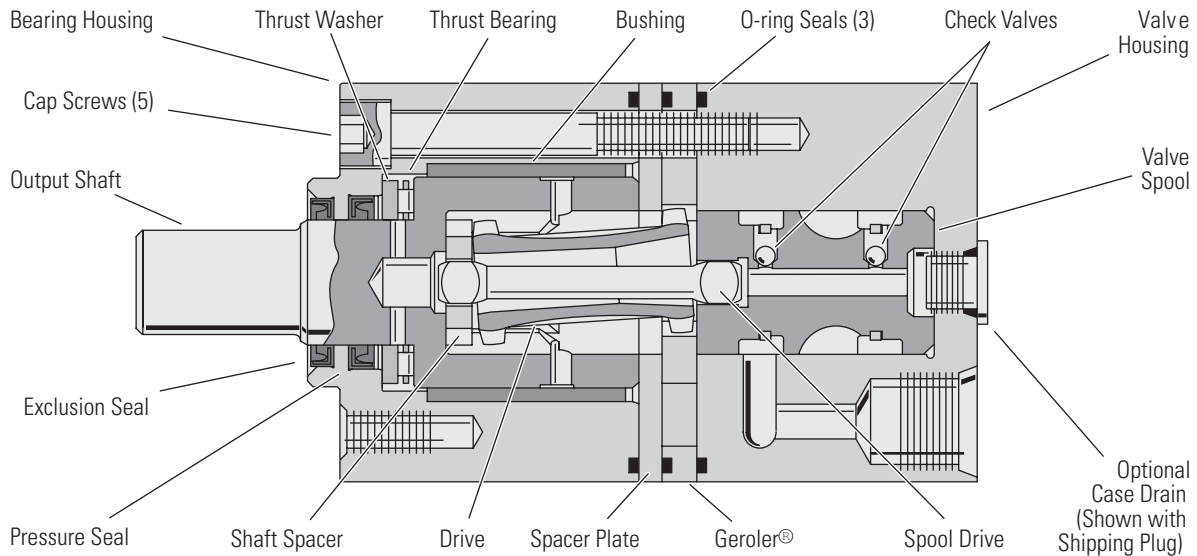

### SPECIFICATION DATA – J MOTORS

Displ. cm <sup>3</sup> /r [in <sup>3</sup> /r]		8,2 [.50]	12,9 [.79]	19,8 [1.21]	31,6 [1.93]	50,0 [3.00]
Max. Speed (RPM) @ Continuous Flow		1992	1575	1043	650	393
Flow l/min [GPM]	Continuous	17 [4.5]	21 [5.5]	21 [5.5]	21 [5.5]	21 [5.5]
	Intermittent	21 [5.5]	25 [6.5]	25 [6.5]	25 [6.5]	25 [6.5]
Torque Nm [lb-in]	Continuous	16 [141]	25 [225]	38 [333]	50 [446]	62 [549]
	Intermittent	19 [164]	30 [263]	46 [405]	62 [546]	84 [743]
	Peak	22 [193]	36 [321]	48 [425]	83 [733]	86 [765]
Pressure Δ bar [Δ PSI]	Continuous	140 [2030]	140 [2030]	140 [2030]	121 [1750]	97 [1400]
	Intermittent	165 [2400]	165 [2400]	165 [2400]	150 [2175]	140 [2030]
	Peak	220 [3190]	220 [3190]	220 [3190]	190 [2756]	150 [2175]
Weight kg [lbs]		2 [4.4]	2,1 [4.6]	2,2 [4.8]	2,3 [5.0]	2,4 [5.4]

\* Maximum pressure at motor inlet port is 220 Bar [3190 PSI] without regard to Δ bar [Δ PSI] and/or back pressure ratings or combination thereof.

#### Note:

To assure best motor life, run motor for approximately one hour at 30% of rated pressure before application to full load. Be sure motor is filled with fluid prior to any load applications.

#### Δ Pressure:

The true Δ bar [Δ PSI] difference between inlet port and outlet port.

See individual shafts for maximum torque recommendation. Splined shafts are recommended for those applications subject to frequent reversals.

#### Continuous Rating:

Motor may be run continuously at these ratings

#### Intermittent Operation:

10% of every minute

#### Peak Operation:

1% of every minute

#### Recommended Fluids:

Premium quality, anti-wear type hydraulic oil with a viscosity of not less than 70 SUS at operating temperature.

#### Recommended System Operating Temp.:

-34°C to 82°C  
[-30°F to 180°F]

#### Recommended Filtration:

per ISO Cleanliness Code 4406, level 20/18/13

# J Series (129-)

## Performance Data

Motors run with high efficiency in all areas designated with a number for torque and speed. For best motor life select a motor to run with a torque and speed range shown in the light shaded area.

Performance data is typical at 120 SUS. Actual data may vary slightly from motor to motor in production.

8,2 cm<sup>3</sup>/r [.50 in<sup>3</sup>/r]

D Pressure Bar [PSI]

Continuous

Max. Continuous

Max. Intermittent

		[200] 14	[400] 28	[500] 34	[600] 41	[700] 48	[800] 55	[1000] 69	[1400] 97	[1500] 103	[2000] 138	[2030] 140	[2400] 165
Flow LPM [GPM]	[1] 3,8	[11] 1 456	[25] 3 444	[33] 4 437	[40] 5 429	[47] 5 422	[55] 6 412	[69] 8 394	[96] 11 347	[102] 12 332	[130] 15 250	[132] 15 239	[146] 16 170
	[2] 7,6	[9] 1 897	[24] 3 886	[31] 4 877	[38] 4 867	[46] 5 860	[53] 6 847	[68] 8 823	[97] 11 768	[105] 12 749	[139] 16 657	[141] 16 647	[163] 18 557
	[3] 11,4	[6] 1 1349	[20] 2 1331	[28] 3 1318	[35] 4 1309	[44] 5 1296	[51] 6 1285	[65] 7 1261	[94] 11 1198	[102] 12 1176	[137] 15 1070	[139] 16 1060	[164] 19 959
	[4.25] 16,0		[16] 2 1902	[23] 3 1885	[30] 3 1873	[36] 4 1858	[44] 5 1846	[60] 7 1817	[90] 11 1750	[97] 12 1721	[133] 15 1599	[135] 15 1585	[160] 18 1475
Max. Continuous	[4.5] 17,0		[16] 2 1992	[23] 3 1979	[29] 3 1964	[36] 4 1947	[43] 5 1929	[59] 7 1900	[89] 10 1833	[96] 11 1808	[131] 15 1684	[134] 15 1673	[160] 18 1553
	Max. Intermittent 20,8		[12] 1 2458	[18] 2 2437	[26] 3 2420	[33] 4 2405	[40] 5 2387	[54] 6 2353	[83] 9 2272	[92] 10 2255	[124] 14 2134	[129] 15 2115	[154] 17 1994

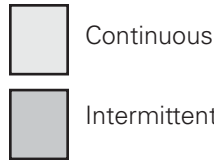

12,9 cm<sup>3</sup>/r [0.79 in<sup>3</sup>/r]

D Pressure Bar [PSI]

Continuous

Max. Continuous

Max. Intermittent

		[200] 14	[400] 28	[500] 34	[600] 41	[700] 48	[800] 55	[1000] 69	[1400] 97	[1450] 100	[1500] 103	[2000] 138	[2030] 140	[2400] 165
Flow LPM [GPM]	[1] 3,8	[19] 2 290	[43] 5 285	[54] 6 281	[65] 7 277	[76] 9 273	[88] 10 268	[109] 12 260	[154] 17 237	[159] 18 234	[164] 19 230	[214] 24 194	[217] 25 189	[250] 28 151
	[2] 7,6	[16] 2 573	[39] 4 566	[51] 6 561	[63] 7 555	[74] 8 549	[86] 10 544	[109] 12 534	[155] 18 501	[160] 19 496	[165] 20 490	[221] 25 442	[225] 25 437	[263] 30 396
	[3] 11,4	[11] 1 859	[35] 4 849	[47] 5 843	[58] 7 838	[70] 8 832	[82] 9 825	[105] 12 810	[152] 17 777	[157] 18 771	[163] 19 763	[219] 25 708	[223] 25 701	[263] 30 652
	[4] 15,1	[6] 1 1153	[30] 3 1140	[41] 5 1135	[53] 6 1129	[64] 7 1124	[76] 9 1117	[99] 11 1101	[146] 16 1060	[152] 17 1051	[157] 18 1044	[214] 24 982	[217] 25 975	[260] 29 924
Max. Continuous	[5.5] 20,8		[19] 2 1575	[30] 3 1566	[42] 5 1556	[54] 6 1547	[65] 7 1539	[89] 10 1521	[136] 15 1473	[142] 16 1466	[148] 17 1457	[205] 23 1396	[209] 24 1387	[251] 28 1330
	Max. Intermittent 24,6		[11] 1 1859	[23] 3 1851	[35] 4 1842	[46] 5 1831	[56] 6 1820	[81] 9 1804	[130] 15 1755	[135] 15 1743	[140] 16 1734	[198] 22 1670	[202] 23 1663	[243] 27 1599

[42] Torque [lb-in]  
5 Nm  
1556 Speed RPM

# J Series (129-)

## Performance Data

Motors run with high efficiency in all areas designated with a number for torque and speed. For best motor life select a motor to run with a torque and speed range shown in the light shaded area.

Performance data is typical at 120 SUS. Actual data may vary slightly from motor to motor in production.

19.8 cm<sup>3</sup>/r [1.21 in<sup>3</sup>/r]

D Pressure Bar [PSI]

Continuous

Max. Continuous

Max. Intermittent

		[200] 14	[400] 28	[500] 34	[600] 41	[700] 48	[800] 55	[1000] 69	[1400] 97	[1450] 100	[1500] 103	[2000] 138	[2030] 140	[2400] 165
Flow LPM [GPM]	[1] 3,8	[32] 4 189	[67] 8 187	[85] 10 186	[102] 12 185	[119] 13 183	[136] 15 182	[170] 19 179	[236] 27 172	[244] 28 170	[253] 29 169	[321] 36 141	[325] 37 138	[374] 42 114
	[2] 7,6	[30] 3 379	[65] 7 375	[83] 9 373	[101] 11 370	[119] 13 368	[136] 15 366	[172] 19 361	[223] 25 351	[248] 28 349	[257] 29 347	[328] 37 312	[333] 38 309	[388] 44 285
	[3] 11,4	[21] 2 569	[57] 6 565	[75] 8 563	[93] 11 560	[111] 13 558	[128] 14 556	[163] 18 551	[231] 26 529	[240] 27 526	[248] 28 523	[325] 37 487	[330] 37 484	[405] 46 459
	[4] 15,1	[12] 1 761	[47] 5 758	[65] 7 754	[83] 9 751	[101] 11 749	[119] 13 746	[154] 17 741	[221] 25 717	[230] 26 711	[239] 27 707	[316] 36 660	[320] 36 656	[382] 43 628
Max. Continuous	[5.5] 20,8	[31] 4 1043	[49] 6 1040	[67] 8 1035	[84] 9 1033	[101] 11 1028	[137] 15 1021	[202] 23 997	[211] 24 993	[218] 25 990	[295] 33 938	[299] 34 934	[365] 41 899	
Max. Intermittent	[6.5] 24,6	[21] 2 1226	[38] 4 1222	[56] 6 1219	[74] 8 1215	[91] 10 1211	[126] 14 1204	[189] 21 1179	[196] 22 1174	[206] 23 1169	[278] 31 1121	[283] 32 1117	[347] 39 1079	

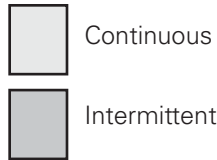

31.6 cm<sup>3</sup>/r [1.93 in<sup>3</sup>/r]

D Pressure Bar [PSI]

Continuous

Max. Continuous

Max. Intermittent

		[200] 14	[400] 28	[500] 34	[600] 41	[700] 48	[800] 55	[1000] 69	[1400] 97	[1450] 100	[1500] 103	[1750] 121	[2175] 150
Flow LPM [GPM]	[1] 3,8	[51] 6 118	[106] 12 116	[133] 15 115	[160] 18 113	[187] 21 112	[213] 24 111	[265] 30 107	[362] 41 91	[372] 42 85	[383] 43 81	[439] 50 70	
	[2] 7,6	[46] 5 236	[103] 12 234	[132] 15 232	[159] 18 230	[187] 21 228	[214] 24 225	[269] 30 221	[362] 41 187	[374] 42 179	[387] 44 175	[446] 50 165	[546] 62 145
	[3] 11,4	[36] 4 355	[94] 11 352	[122] 14 349	[149] 17 347	[177] 20 345	[205] 23 342	[259] 29 336	[351] 40 296	[364] 41 292	[377] 43 287	[440] 50 273	[542] 61 245
	[4] 15,1	[24] 3 474	[79] 9 472	[107] 12 469	[135] 15 466	[162] 18 462	[190] 21 460	[246] 28 452	[337] 38 404	[349] 39 397	[362] 41 393	[425] 48 373	[528] 60 346
Max. Continuous	[5.5] 20,8	[55] 6 650	[83] 9 647	[111] 13 645	[139] 16 640	[167] 19 636	[221] 25 629	[307] 35 584	[320] 36 580	[334] 38 575	[400] 45 550	[505] 57 513	
Max. Intermittent	[6.5] 24,6	[35] 4 767	[64] 7 764	[93] 11 760	[121] 14 755	[150] 17 751	[204] 23 742	[279] 32 712	[294] 33 707	[308] 35 701	[378] 43 675	[485] 55 637	

50.0 cm<sup>3</sup>/r [3.00 in<sup>3</sup>/r]

D Pressure Bar [PSI]

Continuous

Max. Continuous

Max. Intermittent

		[200] 14	[400] 28	[500] 34	[600] 41	[700] 48	[800] 55	[1000] 69	[1100] 76	[1200] 83	[1300] 90	[1400] 97	[2030] 140
Flow LPM [GPM]	[1] 3,8	[82] 9 75	[167] 19 72	[211] 24 72									
	[2] 7,6	[70] 8 149	[156] 18 147	[201] 23 145	[243] 28 144	[286] 32 143	[327] 37 142						
	[3] 11,4	[53] 6 221	[140] 16 220	[184] 21 218	[227] 26 217	[271] 31 215	[311] 35 213	[396] 45 209	[441] 50 205	[484] 55 201	[521] 59 200	[549] 62 191	
	[4] 15,1	[30] 3 296	[120] 14 292	[162] 18 289	[204] 23 286	[250] 28 284	[292] 33 282	[374] 42 273	[419] 47 270	[460] 52 265	[501] 57 263	[541] 61 259	[743] 84 213
Max. Continuous	[5.5] 20,8	[81] 9 393	[127] 14 392	[170] 19 389	[214] 24 387	[254] 29 383	[339] 38 377	[379] 43 372	[422] 48 369	[463] 52 364	[506] 57 358	[702] 79 302	
Max. Intermittent	[6.5] 24,6	[47] 5 465	[90] 10 462	[133] 15 460	[176] 20 458	[219] 25 455	[307] 35 448	[345] 39 445	[385] 43 440	[429] 48 435	[467] 53 430	[685] 77 364	

[81]  
9 } Torque [lb-in]  
393 } Nm  
Speed RPM

# J Series (129-)

## Dimensions

### Standard Rotation Viewed from Shaft End

Port A Pressurized — CW

Port B Pressurized — CCW

### 9/16 Inch End Port

9/16 -18 UNF - 2B O-Ring Ports, M14 x 1,5  
 - 6H O-Ring Ports — Metric Motor or  
 G 1/4 (BSP) Ports (2 Ports each)

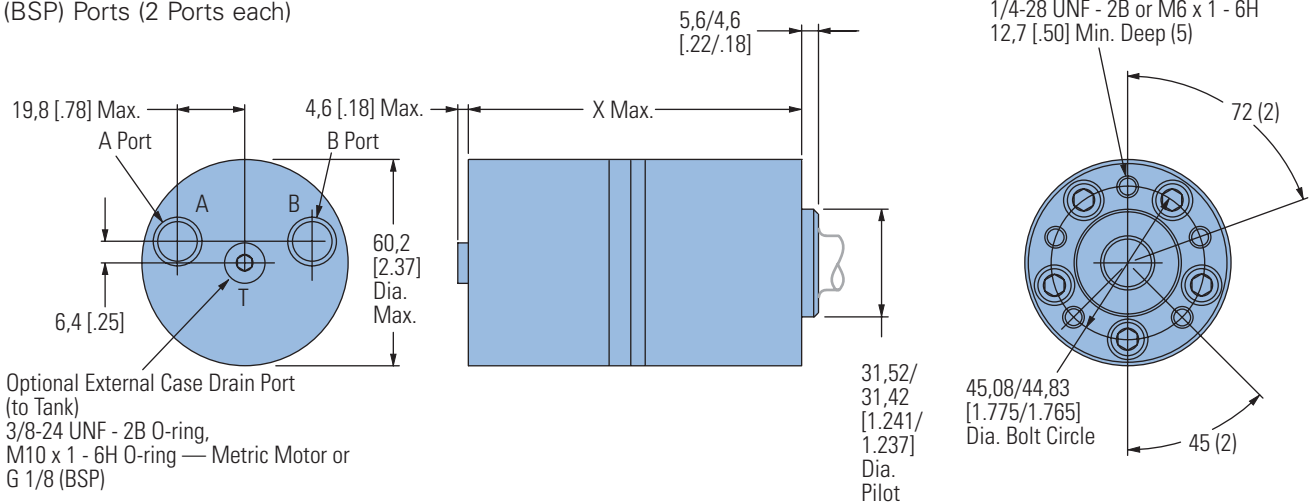

#### END PORT DIMENSIONS

Displacement cm <sup>3</sup> /r [in <sup>3</sup> /r]	X mm [inch]
8,2 [ .50]	103,9 [4.09]
12,9 [ .79]	106,9 [4.21]
19,8 [1.21]	112,5 [4.38]
31,6 [1.93]	118,9 [4.68]
50,0 [3.00]	130,3 [5.13]

### 3/8 Inch End Port

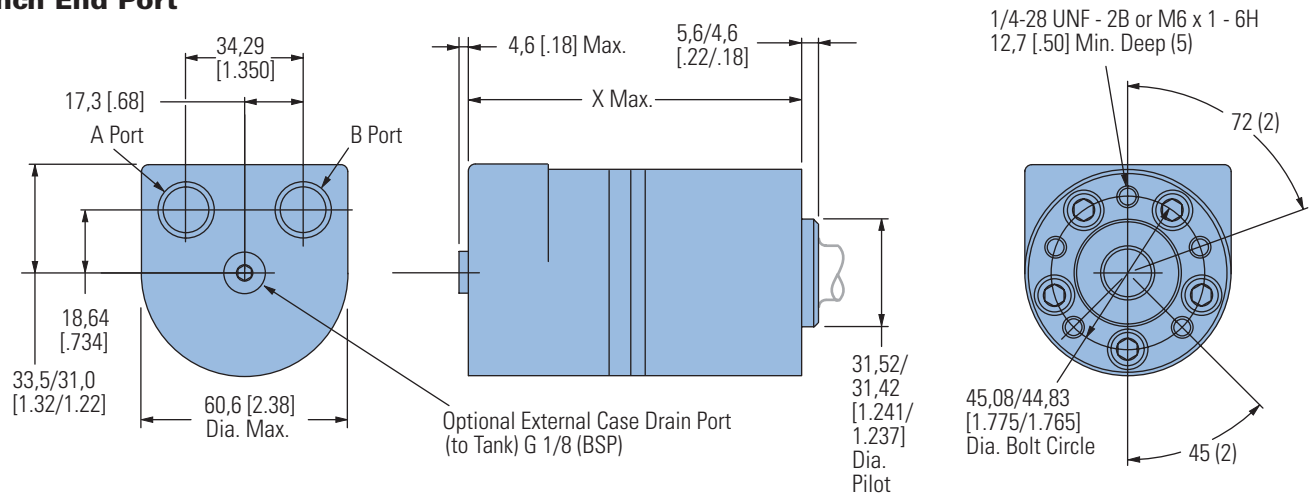

#### END PORT DIMENSIONS

Displacement cm <sup>3</sup> /r [in <sup>3</sup> /r]	X mm [inch]
8,2 [ .50]	103,9 [4.09]
12,9 [ .79]	106,9 [4.21]
19,8 [1.21]	112,5 [4.38]
31,6 [1.93]	118,9 [4.68]
50,0 [3.00]	130,0 [5.12]
160,5 [6.32]	132,3 [5.21]

# J Series (129-)

## Dimensions

### Ports

9/16 -18 UNF - 2B O-Ring Ports,  
M14 x 1,5 -6H O-Ring Ports — Metric Motor,  
G 3/8 or G 1/4 (BSP) Ports (2)

### Standard Rotation Viewed from Shaft End

Port A Pressurized — CW

Port B Pressurized — CCW

## Side Port

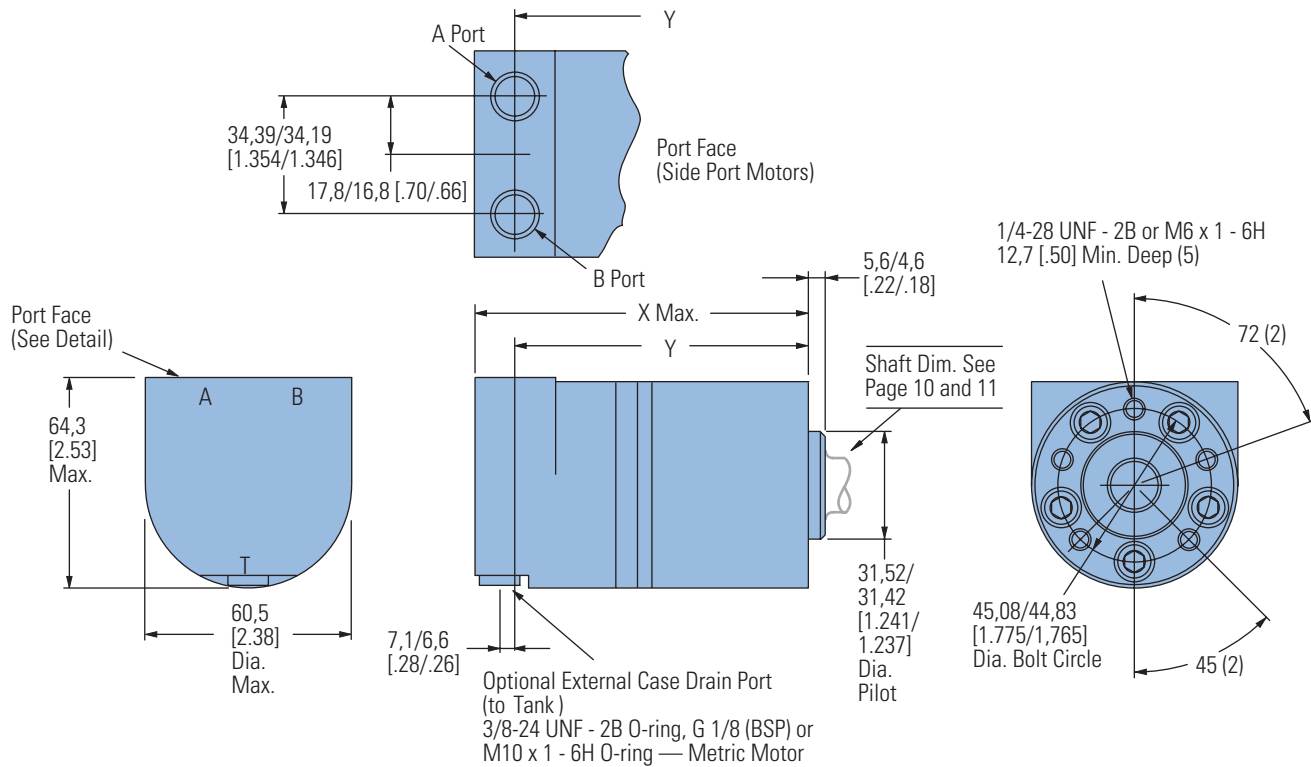

### SIDE PORT MOTORS

Displacement cm <sup>3</sup> /r [in <sup>3</sup> /r]	X mm [inch]	Y mm [inch]
8,2 [.50]	103,9 [4.09]	89,4/ 87,4 [3.52/3.44]
12,9 [.79]	106,9 [4.21]	92,5/ 90,4 [3.64/3.56]
19,8 [1.21]	112,5 [4.38]	96,8/ 94,7 [3.81/3.73]
31,6 [1.93]	118,9 [4.68]	104,4/102,4 [4.11/4.03]
50,0 [3.00]	130,0 [5.12]	115,7/113,9 [4.56/4.48]

# J Series (129-)

## Dimensions

### Shafts

### 5/8 Inch Straight Keyed

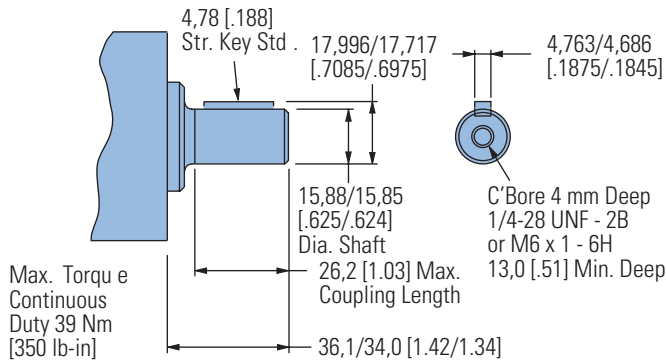

### 11/16 Inch Straight Keyed

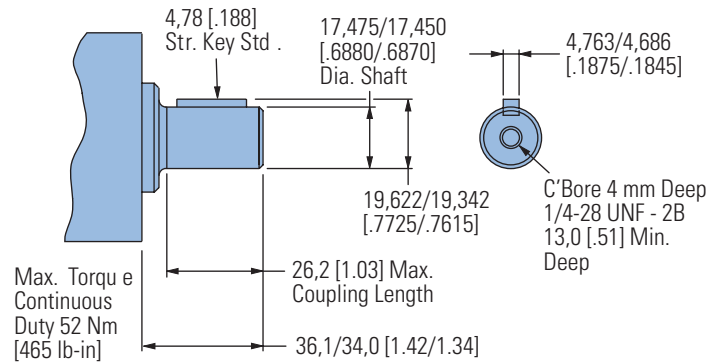

### 5/8 Inch Straight Keyed w/ Crosshole

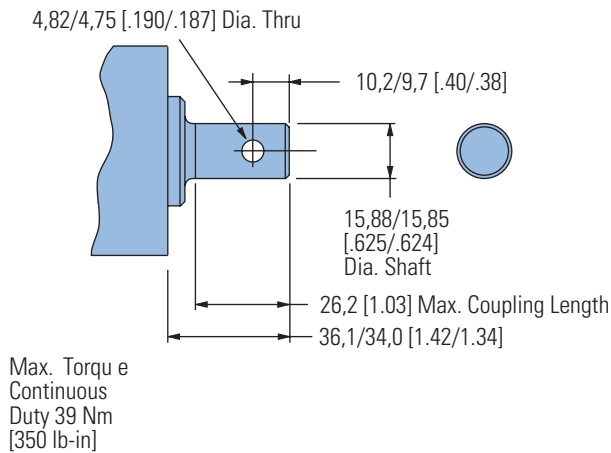

### 3/4 Inch Tapered

(Tapered Shaft End Per SAE J744)

Except as Specified — 1.5 : 12 Ratio)

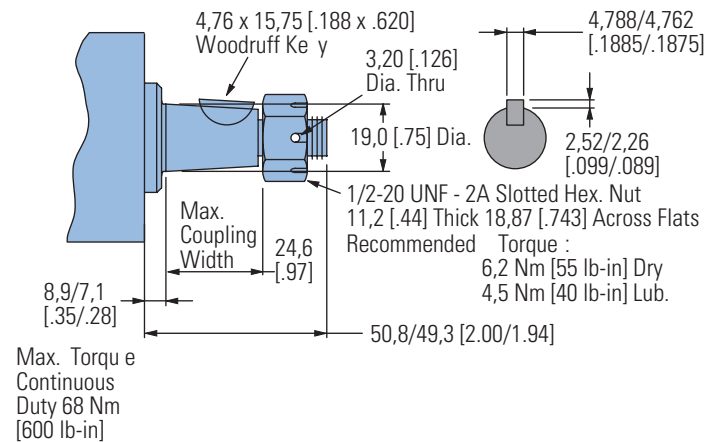

# J Series (129-)

## Dimensions

### Shafts and Flange Kit

#### 16 mm Straight Keyed

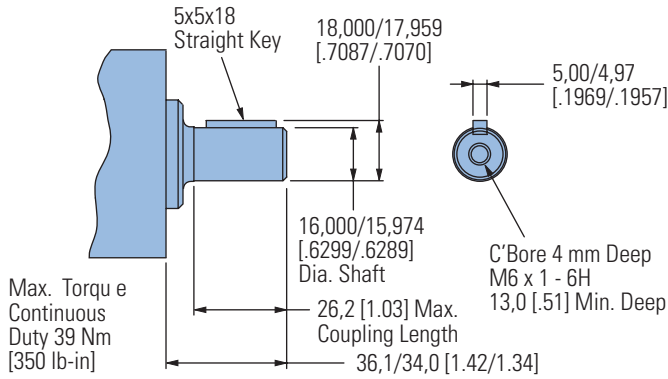

#### 18 mm Straight Keyed

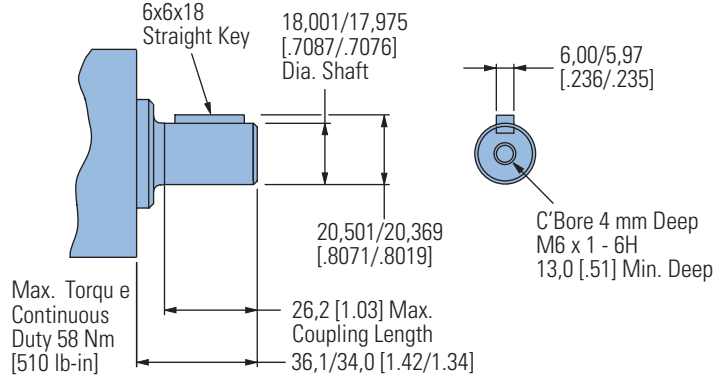

#### Involute 9T Splined – Metric

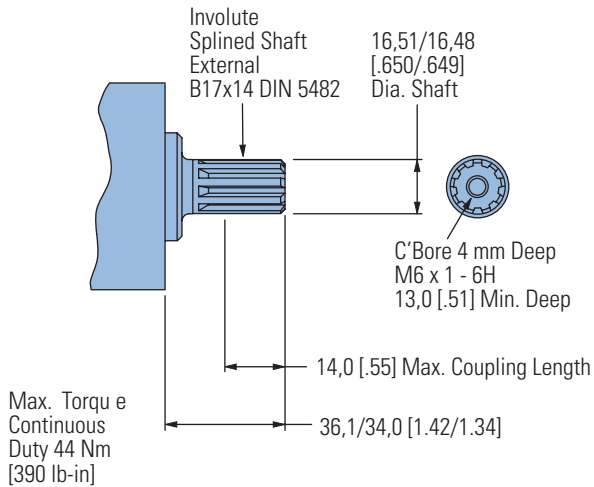

#### 2 Bolt Flange Kits (2)

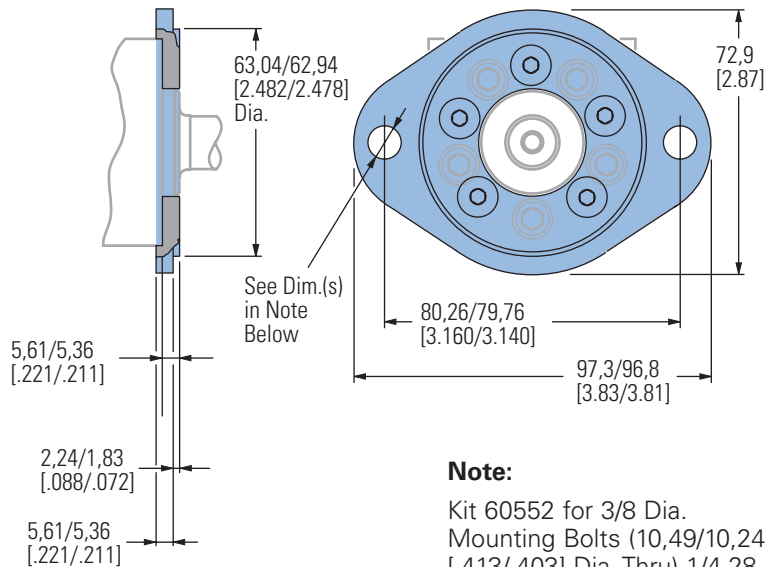

#### Note:

Kit 60552 for 3/8 Dia. Mounting Bolts (10,49/10,24 [0.413/0.403] Dia. Thru) 1/4-28 UNF screws for attaching flange to motor (5)

Kit 60553 for M8 Dia. Mounting Bolts (9,12/8,86 [0.359/0.349] Dia. Thru) M6 x 1 - 6H screws for attaching flange to motor (5)

# J Series (129-)

Product Numbers

Use digit prefix —  
129- plus four digit number  
from charts for complete  
product number—  
Example 129-0479.

**Orders will not be accepted  
without three digit prefix.**

B-1

## End Port

MOUNTING	SHAFT	PORT SIZE	DISPL. cm <sup>3</sup> /r [in <sup>3</sup> /r] / PRODUCT NUMBER				
			8,2 [.50]	12,9 [.79]	19,8 [1.21]	31,6 [1.93]	50,0 [3.00]
1/4-28 UNF 2B	5/8 inch Straight		129-0291	-0292	-0293	-0294	-0458
	11/16 inch Straight	9/16 -18 UNF 2B O-Ring (2)	129-0295	-0296	-0297	-0298	-0459
	Splined — Metric		129-0299	-0300	-0301	-0302	-0460
	3/4 inch Tapered		129-0480				
M6 x 1 - 6H	16 mm Straight	M14 x 1,5 - 6H O-Ring (2)	129-0303	-0304	-0305	-0306	-0461
	18 mm Straight		129-0307	-0308	-0309	-0310	-0462
	Splined — Metric		129-0311	-0312	-0313	-0314	-0463
	16 mm Straight	G 1/4 (BSP) (2)	129-0315	-0316	-0317	-0318	-0464
	18 mm Straight		129-0319	-0320	-0321	-0322	-0465
	Splined — Metric		129-0323	-0324	-0325	-0326	-0466
	16 mm Straight		129-0327	-0328	-0329	-0330	-0467
	18 mm Straight		G 3/8 (BSP) (2)*	129-0331	-0332	-0333	-0334
Splined — Metric	129-0335	-0336		-0337	-0338	-0469	

\*Note: The Same Casting used for Side Ports is Required for G 3/8 (BSP) End Ports

129-0336

## Side Port

MOUNTING	SHAFT	PORT SIZE	DISPL. cm <sup>3</sup> /r [in <sup>3</sup> /r] / PRODUCT NUMBER					
			8,2 [.50]	12,9 [.79]	19,8 [1.21]	31,6 [1.93]	50,0 [3.00]	
1/4-28 UNF 2B	5/8 inch Straight		129-0339	-0340	-0341	-0342	-0470	
	11/16 inch Straight	9/16 -18 UNF 2B O-Ring (2)	129-0343	-0344	-0345	-0346	-0471	
	Splined — Metric		129-0347	-0348	-0349	-0350	-0472	
	3/4 inch Tapered		129-0481					
M6 x 1 - 6H	16 mm Straight	M14 x 1,5 - 6H O-Ring (2)	129-0351	-0352	-0353	-0354	-0473	
	18 mm Straight		129-0355	-0356	-0357	-0358	-0474	
	Splined — Metric		129-0359	-0360	-0361	-0362	-0475	
	16 mm Straight	G 1/4 (BSP) (2)	129-0363	-0364	-0365	-0366	-0476	
	18 mm Straight		129-0367	-0368	-0369	-0370	-0477	
	Splined — Metric		129-0371	-0372	-0373	-0374	-0403	
	16 mm Straight		G 3/8 (BSP) (2)	129-0375	-0376	-0377	-0378	-0478
	18 mm Straight			129-0379	-0380	-0381	-0382	-0479

Two Bolt Mounting Flange Kit (for 3/8 inch Mounting Bolts) — Kit Number 60552 (includes 5 screws — 1/4 -28 UNF-2B)

Two Bolt Mounting Flange Kit (for M8 Mounting Bolts ) — Kit Number 60553 (includes 5 screws — M6 x 1-6H)



# J Series (129-)

## Shaft Side Load Capacity

The hydrodynamic bearing has infinite life when shaft load ratings are not exceeded. Hence, the shaft side load capacity is more than adequate to handle most externally applied loads (such as belts, chains, etc.), providing the motor to shaft size is applied within its torque rating.

Allowable side load chart, shaft load location drawing (right) and load curves (below) are based on the

side or radial loads being applied to shaft at locations A, B, and C, to determine the shaft side load capacity at locations other than those shown use the formula (shown below). For more information about shaft side loads on Char-Lynn motors contact your Eaton representative.

### ALLOWABLE SIDE LOAD – KG [LB]

RPM	A	B	C
2300	29 [ 64]	24 [ 53]	20 [ 43]
1500	44 [ 98]	37 [ 82]	30 [ 66]
1250	54 [118]	44 [ 98]	36 [ 79]
1000	67 [147]	55 [122]	45 [ 99]
750	89 [196]	74 [163]	60 [132]
600	111 [245]	93 [204]	75 [165]
500	133 [294]	111 [245]	90 [198]
400	167 [368]	139 [306]	112 [248]
340	196 [432]	163 [360]	132 [291]

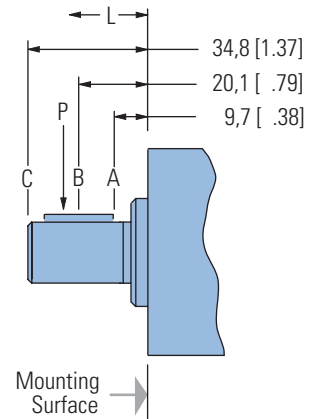
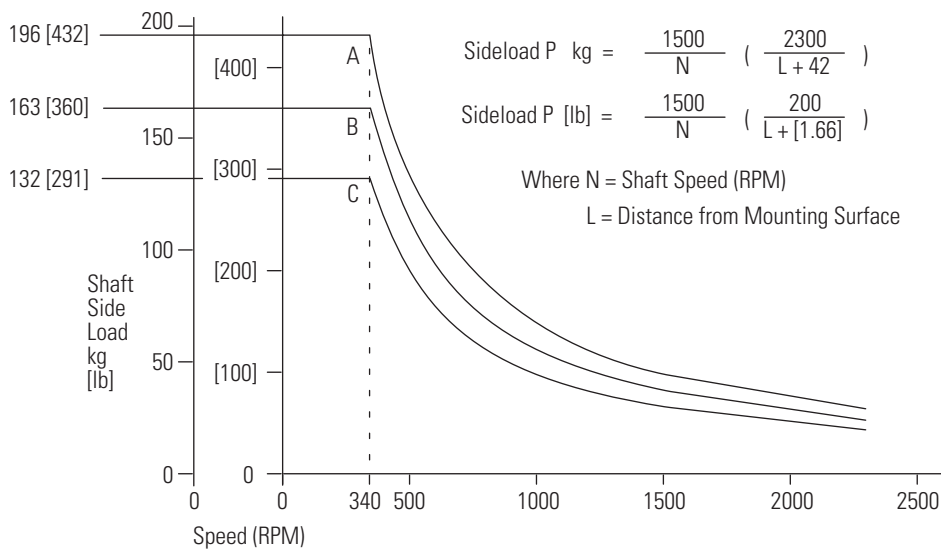

# J Series (129-)

## Case Pressure and Case Drain

The J Series now offers check valves in the motor as a standard feature. This addition reduces the case pressure in the motor to the return pressure of the system when the case drain is not used. For return pressures higher than the rated pressures (see chart) the external case drain can be connected. If the case drain line is needed, connect drain line to assure that the motor will always remain full of fluid.

### Case Drain Advantage

In addition to providing lower case pressures for motors connected in series, there are advantages for adding an external case drain line to motors with normal case pressures as well. These advantages are:

**Contamination Control** — flushing the motor case.

**Motor Cooler** — exiting oil draws motor heat away.

**Extend Motor Seal Life** — maintain low case pressure with a preset restriction installed in the case drain line

### Example:

A 14 Bar case pressure will cause a load of 40 kg, so the allowable thrust load will be 82 kg plus 40 = 120 kg pushing inward on shaft. Tension load is 82 kg under all case pressure conditions.

### Example:

A 200 PSI case pressure will cause a load of 88 lbs, so the allowable thrust load will be 180 lbs plus 88 = 268 lbs pushing inward on shaft. Tension load is 180 lb under all case pressure conditions

### Note:

J Series motors can be connected in parallel or in series.

Case pressure will add to the allowable compressive thrust load. Case pressure will push outward on the shaft at 20 kg/7 Bar [44 lb/100 PSI].

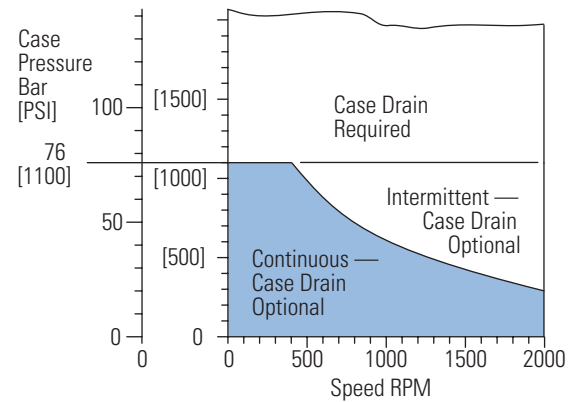
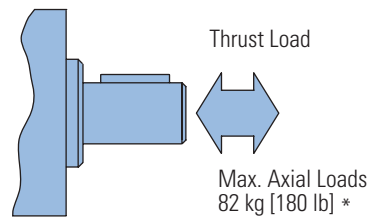
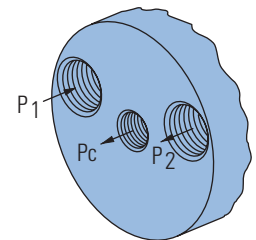

Case Pressure Seal Limitation